



BRITISH MODEL FLYING ASSOCIATION

CONTEST RULES

SECTION 4

CONTROL LINE

SPEED AEROBATICS

TEAM RACING COMBAT CARRIER

To be read in conjunction with the General Rules, Sections 1 and 2, which are available free of charge from the BMFA

Effective January 2014

Supersedes January 2013 Issue

Price £3.00

SECTION 4 - CONTROL LINE RULE BOOK 2014

CONTENTS

NOTE: Control Line Books 1 and 2 have been combined into this book and all FAI class rules have been deleted where they are a copy of the FAI Sporting Code (see detail note below).

4.0.1	General Rules.....	3
4.0.2	<i>Deleted (FAI F2 World Cup)</i>	
4.0.3	Team Selection Rules	4
4.0.4	Domestic Team Rules for F2D Combat.....	9
	Safety Strap Notice.....	9
4.1.2	BMFA Variations on F2A	10
4.1.3	BMFA Control Line Speed Rules.....	10
4.1.4	Sport Jet Speed.....	15
4.1.7	The F2A and Open Speed Leagues.....	17
4.1.5	Vintage Speed	18
4.1.6	Vintage Proto Speed	21
4.1.9	Weatherman Speed.....	21
4.2.2	BMFA variations on F2B.....	23
	BMFA Variations of F2B Judges Guide.....	24
4.2.8	C/L Technical Committee Aerobatics Judges Training Programme.....	24
4.2.3	Class 2 Aerobatics.....	26
4.2.4	Junior Class 2 Aerobatics.....	27
4.2.5	Vintage Stunt	27
4.2.6	Classic Aerobatics	36
4.2.7	Gold Trophy Aerobatics.....	37
4.3.2	BMFA Variations on F2C.....	38
4.3.4	General Team Race Rules	38
4.3.5	Semi Scale Class Rules	44
4.3.5.1	1/2A, B and Barton B.....	44
4.3.5.2	1/2A Team Race.....	44
4.3.5.3	B Team Race.....	44
4.3.5.4	Barton B Team Race	45
4.3.6	Profile Class Rules	47
4.3.6.2	Open Goodyear	48
4.3.6.3	British Goodyear.....	49
4.3.6.4	Mini Goodyear	49
4.3.6.5	F2CN	51
4.3.7	Vintage Team Race.....	52
4.3.7.9	Vintage 1/2A Team Race	55
4.3.7.10	Vintage Class A Team Race	56
	<i>cont./...</i>	

.../cont.	
4.3.7.11	Vintage Class B Team Race 59
4.4.2	BMFA Variations on F2D 61
4.4.5	1/2A Combat..... 61
4.4.6	1/2A Diesel Combat..... 67
4.4.7	Vintage Combat..... 67
4.4.8	Oliver Tiger Combat 78
4.4.10	BMFA Variations on F2E 79
4.5.1	Class 1 Carrier Deck 80
4.5.3	Basic Carrier Deck 82

Notes

Changes to the rules are denoted by a side-bar as shown on the right – not the left as previous issues..

Gender

Words of masculine gender should be taken as including the feminine gender unless the context indicates otherwise.

Synopsis of changes.

The rules for FAI classes F2A, F2G, F2B, F2C, F2D and F2E, where they are a direct copy from the FAI Sporting Code, have been deleted from this book. They are available for download at www.fai.org/fai-documents# (then click on Section 4 Aeromodelling and select the set of rules you require). Alternatively they can be obtained from BMFA Head Office.

4.1.3.8 Additional Safety Strap rules.

4.1.3.11 (d) amended and extended and notes added after (e)

4.1.5.2 Additional rules to 'Model'

4.1.5.3 Additional rules to 'Engine'

4.1.5.7 Para. (a) deleted - (b) becomes (a)

4.1.5.12 minor amendment.

4.3.5.4.3 (g) final sentence added

4.3.5.4.6 (a) and (b) amended and (c) deleted

4.3.6.2.1 (a), (c) and (f) deleted. (b) becomes (h) and remainder renumbered accordingly.

4.3.6.2.2 deleted and 4.3.6.2.3 has final note deleted and then renumbered to 4.3.6.2.5.

New paras 4.3.6.2.2, 3, 4 added.

4.3.6.3.2 Rules (a), (b), (c) replaced with new rules and (d) deleted.

4.3.6.3.3 Rules (a) and (b) replaced with new rules and (c) and (d) deleted.

4.3.6.3.5 Deleted

4.3.6.3.6 Renumbered to 4.3.6.3.5 and rules (b), (c) and (d) deleted.

4.3.6.5.1 New rule (c) added.

4.3.6.5.3 Rule (b) deleted and old (c) and (d) renumbered (b) and (c)

4.3.7.4 (d) minor addition.

4.4.7.1 (h) Two new models added

4.4.7.2 (a) Two new engines added.

4.4.8.2 (a) Whole rule replaced.

4.0.1 CONTROL LINE GENERAL CONTEST RULES.

4.0.1.1 Safety Precautions

- (a) No control line model aircraft shall be flown in a contest unless arrangements are made to keep spectators at least 25 feet outside the flight path of the model aircraft unless the model aircraft are flown inside a safety cage.
- (b) No model aircraft or equipment shall be used in a contest if it is considered by the Contest Director to be unsafe or in a dangerous condition.
- (c) Any competitor releasing the controls whilst the model aircraft is in motion shall be under the penalty of disqualification from the contest.
- (d) In ALL CLASSES the use of either a spinner or a safety spinner nut is compulsory.
- (e) Most Classes have specific propeller safety rules and you should refer to the individual class sections for more information.
- (f) It is strongly recommended that safety wrist straps are worn by all pilots during flying including practice flying. These are compulsory under FAI rules for all F2 Classes.

Note: There will be occasions when the wearing of a safety wrist strap during practice flying will be mandatory.

- (g) It is strongly recommended that all mechanics for Team Race, Vintage Team Race and Combat wear safety helmets during practice flying.

Note: There will be occasions when the wearing of a safety helmet during practice flying will be mandatory.

4.0.1.2 With the exception of Open Speed control line model aircraft employing multi-line control, it shall not be permitted to link the two lines together in any way between the point of exit on the model aircraft and a point 300mm from the control handle.

4.0.1.3 The order of flying shall be decided by means of a draw when considered necessary by the organisers.

4.0.1.4 The jettisoning of any part of the model aircraft or attachments in flight is prohibited. In such an occurrence, the flight shall be deemed to be a non-scoring attempt.

4.0.1.5 Other than that exercised by the pilot through the control lines, no other means of controlling the model aircraft or the engine may be employed during the flight.

4.0.1.6 Control Line Contest Records.

Team Race Records.

- (a) Team Race record claims will only be eligible when the flights have been made at:
 - (i) any BMFA Centralised competition;
 - (ii) any competition run by, or on behalf of, a recognised National Body;
 - (iii) any international competition that appears on the FAI International Contest Calendar.
- (b) Only races where 3 (three) aircraft start the heat/final and complete at least 75% of the race will be considered eligible for record claims.

4.0.1.7 Interruption of the Contest

The contest should be interrupted or the start delayed by the Jury in the following circumstances and in other exceptional circumstances decided by the Jury:

BMFA VARIATION to FAI Sporting Code Section 4, rule B.15.1

(a) For Control Line the start of the contest shall be delayed or the contest interrupted if the wind speed is continuously stronger than 9m/s (20mph) for 30 seconds when measured at two metres above the ground at the centre of the circle.

(b) The visibility prohibits proper observation of the models (especially in case of F/F or R/C contest) or due to atmospheric conditions it would be dangerous to continue the competition.

(c) It is necessary to reposition the starting line. This may only take place between rounds, or groups in F3B and F3J.

(d) The prevailing conditions are such that they may lead to unacceptable sporting results.

(e) For F3A, F5A, F3C and F4C contests the sun is in the manoeuvring area.

(f) Any incident affecting safety or requiring access for emergency services.

In the event of an interruption during a round, the Jury must decide the action to be taken to complete, repeat, or cancel the round. The remainder of the round may be completed as soon as conditions allow, with adequate notice given to all competitors and Team Managers.

4.0.1.8 Protests and Appeals

(a) Any competitor wishing to register a protest must do so at the event to the Contest Director (CD).

(b) If not satisfied with the CD's decision the competitor must, at the event, hand him the protest in writing together with a fee of double the standard entry fee. The CD will then immediately empanel a jury of three persons to deal with the protest

(c) The jury's decision is final, subject to the right of the competitor to appeal to the BMFA Council.

(d) Notification that an appeal is pending must be sent by the competitor to the BMFA Competition Secretary to arrive not later than 2 weeks from the date of the event.

(e) The appeal itself, together with any supporting evidence, must be sent to the BMFA Competition Secretary to arrive not later than two months from the date of the event.

(f) If the written protest or appeal is upheld, the protest fee will be returned.

4.0.3 TEAM SELECTION RULES

The team selection competitions will be run throughout the season in the year immediately prior to that in which the World or European Championship will be held.

4.0.3.1 F2A Speed Team Selection Rules

4.0.3.1.1 The team selection contests will be designated as such in the BMFA News Contest Calendar.

4.0.3.1.2 Points will be awarded to the final placings as follows:

First place	=	ten points
Second place	=	seven points
Third place	=	five points
Fourth place	=	four points
Fifth place	=	three points
Sixth place	=	two points
Seventh place	=	one point

4.0.3.1.3 Classification

- (a) A league results table will be maintained and updated after each team selection competition.
- (b) At the end of the season, a summation of the best five place points for each competitor will determine the final team selection points for that competitor.
- (c) In the event of a tie, the best individual officially recorded speed will be used to break the tie. If the tie still exists after this, then the next best individual officially recorded speed will be taken into account and so on until the tie is broken.
- (d) The three top placed fliers will be proposed as the F2A team for the following Championships.
- (e) The fourth placed flier will be proposed as the reserve F2A team member.

4.0.3.2 F2B Aerobatics Team Selection Rules

4.0.3.2.1 The team selection contests will be designated as such in the BMFA News Contest Calendar.

4.0.3.2.2 Points will be awarded to the final placings as follows:

First place	=	ten points
Second place	=	seven points
Third place	=	five points
Fourth place	=	three points
Fifth place	=	two points
Sixth Place	=	one point
Subsequent places	=	nil points

Any F2B flier who judges at a competition that includes F2B Team Selection, thus giving up his opportunity to enter that competition, shall be compensated in the following way:

- (a) He shall be awarded points that are equal to the average of the placings he achieved at the competitions that include F2B Team Selection during that season.
- (b) The points shall be rounded to one decimal place.
- (c) These averaged points shall count for the judged competition.
- (d) In any season, the maximum number of relevant competitions at which an F2B flier may judge, in lieu of flying, is two.
- (e) The calculation shall be made at the end of the flying season.

4.0.3.2.3 Classification

- (a) A league results table will be maintained and updated after each team selection competition.
- (b) At the end of the season, a summation of the best five place points for each competitor will determine the final team selection points for that competitor.
- (c) In the event of a tie, the best individual officially recorded points awarded by the Aerobatic Judge(s) will be used to break the tie. If the tie still exists after this, then the next best individual officially recorded points awarded by the Aerobatic Judge(s) will be taken into account and so on until the tie is broken.
- (d) The three top placed fliers will be proposed as the F2B team for the following Championships.
- (e) The fourth placed flier will be proposed as the reserve F2B team member.

4.0.3.3 F2C Team Race Team Selection Rules

4.0.3.3.1 The two best heat times for each properly constituted team at each team selection competition shall be recorded in a results table which will be maintained and updated after each qualifying competition and published in a timely manner on the CL News page of the BMFA website.

4.0.3.3.2 The Contest Director may, in extreme weather conditions declare, on the day, to run two-up races for that day and the times shall count towards team selection.

4.0.3.3.3 At Team Selection competitions (TSC) where the draw produces a two-up race:

- (a) if there are no teams with re-flights and no volunteer team is available, then the CD will draw a team at random to make a three up-race.
- (b) That team's extra race time shall be counted for Team Selection.
- (c) If no team is willing to participate, then the times that the two remaining teams achieve will count for team selection. A volunteer team may be a "scratch" team, whose result shall not count for Team Selection.
- (d) A "scratch" team is one which is formed on the day and it may contain entrants who have already flown in another team at that competition.

4.0.3.3.4 A maximum of two times shall be taken from any one competition.

4.0.3.3.5 Times shall be eligible only when recorded at:

- (a) The BMFA National Championships.
- (b) Any BMFA competition designated as Team Selection at the start of the season.
- (c) Any competition designated as Team Selection by the Control Line Technical Committee.
- (d) Any UK hosted open international competition.
- (e) Any BMFA competition designated as Team Selection competition held on an appropriately published reserve date.
- (f) A maximum of three FAI Open International competitions that appear on the FAI Contest Calendar with results available from an independent source.

Note: Times from World or Continental Championships do not count.

4.0.3.3.6 Two reserve dates will be published to cover cancellations caused by situations that are beyond the control of the organisers.

- 4.0.3.3.7** Venue changes within a reasonable distance (approximately 150 miles) of the original venue are permitted only on the published date.
- 4.0.3.3.8** The list of eligible Team Selection competitions, including two reserve dates, shall be published on the BMFA website and in the BMFA News Contest Calendar.
- 4.0.3.3.9** To be eligible for Team Selection a team must:
- (a) Enter a minimum of 4 designated competitions excluding the Nats.
 - (b) Unless organising a competition (see item 11) when the minimum number is then reduced to 3, teams shall compete in a minimum of 4 BMFA designated Team Selection competitions excluding the Nationals.
 - (c) Should a competition be cancelled because of weather conditions or some other unavoidable circumstance, the team that volunteered to run that competition will be offered the chance to run the competition on one of the reserve dates if the dates have not already been utilised.
- 4.0.3.3.10** Teams may elect, at the beginning of the year when the Contest Calendar is published, to run one of the Team Selection competitions. Any team that runs one of the Team Selection competitions (AND does not participate in it) will only have to record 6 and not 8 times. Only one member of the team is required to run the competition.
- 4.0.3.3.11 Final Team Selection**
- (a) At the end of the season, the best 8 recorded times of each team will be averaged. The resulting average time shall be made up to the next upper 1/10 of a second and listed in the Team Selection table in ascending order (fastest, first; slowest, last). This order shall determine the placings for team selection.
 - (b) In the event of a tie, the best individual officially recorded time of the eight times used to calculate the average time will be used to break the tie. If the tie still exists after this, then the next best individual officially recorded time of the eight times will be taken into account and so on until the tie is broken.
 - (c) The three top placed teams will be proposed as the F2C team for the following Championships.
 - (d) The fourth placed team will be proposed as the reserve F2C team.
- 4.0.3.4 F2D Combat Team Selection Rules**
- 4.0.3.4.1 Contests**
- (a) The team selection contests will be designated as such in the BMFA News Contest Calendar.
 - (b) Qualifying competitions shall be all five team selection contests and the Nationals plus a maximum of one foreign competition excluding World & European Championships (they are not open competitions).
 - (c) For a foreign contest to be included, it must appear on the FAI Calendar either as a World Cup or an Open International and the results must be available from an independent source.
 - (d) The season will be deemed to have finished at the end of the last scheduled contest unless a flier has notified the F2D CD (currently John James) that he plans to attend a foreign contest after that date and that he wishes to earn team points from that contest. The CD needs to be notified, at the very latest, immediately after the last bout of the final team selection contest otherwise the foreign contest shall not be counted.

4.0.3.4.2 Team Points

- (a) Points are accrued on the following basis:
 - (i) 1 point for each team selection contest entered, plus 1 point for entering the Nationals.
 - (ii) In the event of a contest being cancelled on the day at the flying site, those fliers who turn up will get an attendance point; a second attendance point shall be accrued if they also turn up at the re-scheduled competition.
 - (iii) 1 point for entering a foreign F2D competition. Only 1 foreign attendance point may be accrued, no matter how many foreign contests are entered.
 - (iv) In order to qualify for the UK attendance point, the flier must stay on the field, to help out with the organisation if required, until the end of the event. (This requirement may be waived in any case of extenuating circumstances.)
 - (v) 1 "win" point for each bout won, when a bout is flown, during any qualifying competition including a maximum of one foreign competition.
- (b) The summation of the best 6 scores of each competitor shall determine the final points for that competitor. This means that if a flier does not attend a foreign contest, all 5 team selection contests plus the nationals will be have to be counted. If any points have to be dropped, then they shall be "win" points; attendance points shall be retained.
- (c) All fliers who wish to be considered for the British Team for the next Championships shall attend and compete in the last competition of the season. (This requirement may be waived in the case of extenuating circumstances.)
- (d) The three fliers with the most points will be proposed as the F2D team.

4.0.3.4.3 Tie-Break

- (a) In the case of a tie of points for the final team place(s) at the end of the season, there shall be a fly-off between the pilots involved. This shall be a one-off bout held at the end of the final team selection contest. If more than two fliers are tied, then they shall all fly against each other in a "round robin" until a winner is, or winners are, found.
- (b) If, after the final bout of the last team selection contest, any flier involved in a tie elects to attend a later foreign contest, and if this might affect the people involved in this fly off for the final team places, then the fly-off shall be re-scheduled to take place on the first reserve date.
- (c) Should it be impossible to hold a fly-off for reasons such as weather, then there will be a count back of actual placings during the season, counting the number of first places initially and then if the result is still tied, counting the number of second places and so on.

4.0.4

DOMESTIC TEAM RULES FOR F2D COMBAT

- (a) A Domestic Team (DT) will consist of no more than four pilots.
- (b) The sole purpose of a DT is to enable fliers from the same team to be kept apart in the draw for the first two rounds only.
- (c) A flier must nominate his DT with his first entry of the season.
- (d) A flier may join only one DT throughout the flying season.
- (e) A flier may elect to leave that DT if he wishes but may not then join another DT. Additionally that DT cannot replace him.
- (f) A flier does not have to be a member of any DT.
- (g) If a flier does not select a DT at the time of his first entry, he will be considered to be a solo entrant for the remainder of the season.
- (h) DT members will be drawn apart from each other when possible for the first two rounds only. After that, the draws will continue in the usual way.

NOTE

In accordance with ABR 1.3.2 for all F2 classes a safety strap connecting the competitor's wrist to the control handle must be provided by the competitor and used during all flights A pull test shall be applied separately to the safety strap. This pull test will be applied according to each class specification concerning the lines' pull test.

4.1.2 BMFA VARIATIONS ON F2A

See Section 4.1.3, BMFA Control Line Speed Rules below

4.1.3 BMFA CONTROL LINE SPEED RULES

4.1.3.2 Definition of speed models

TABLE A

BMFA Class	Engine Capacity (cm ³)	Min. Diameter of Lines (mm)		Radius of Flight (metres)	Number of Laps (1 km)	Max Dry Weight (grams)	Pull Test (kg)
		Monoline	2 Line				
.049	0 - 0.9	0.30	0.25	14.15	6 (0.53 km)	250	10
0.12	0.9 - 2.1	N/A	0.30	14.47	11	450	15
0.15	1.51 - 2.5	0.50	0.40	17.69	9	550	30
FAI	Max 2.5	N/A	0.40	17.69	9	n/a	50G
F21	2.51 - 3.5	N/A	0.45	17.69	9	700	30
21N	2.51 - 3.5	N/A	0.40	15.92	10	700	25
0.29	3.51 - 5.0	0.60	0.45	19.90	8	1050	40
0.40	5.01 - 7.0	0.60	0.50	19.90	8	900	40
F40	5.01 - 7.0	N/A	0.50	19.90	8	1050	40
0.60 Light	7.01 - 10.0	0.75	0.55	19.90	8	1100	55
0.60 Heavy	7.01 - 10.0	0.75	N/A	19.90	8	1300	65
Fast Jet		0.75	0.60	19.90	8	1150	65
	At its minimum diameter, the tailpipe shall not be greater than 806.45mm ² (1.25in ²).						
Sport Jet		N/A	0.55	17.69	9	1150	45

NOTES

- (i) Class 0.12, is for commercially available engines up to 2.1 cc (0.13 in³), no tuned or mini pipes are to be used. Only two bladed propellers are allowed.
- (ii) For the Jet classes, an additional allowance of 200gm for fuel has been taken into account to determine the correct pull test.

4.1.3.3 Qualification of Competitors

- (a) Entry to any BMFA control line speed class is unrestricted except for the following:
- (b) Class 21N Entrants of Class 21N models will be competitors who have not previously achieved more than 80% of any national speed record, other than Class 21N, and who have not, in the 12 months preceding the present contest, exceeded the then current 21N national record in any official competition.

- (c) It is not mandatory that the entrant flies the model. If the entrant elects not to fly the model, then only he may adjust or set the engine and the designated pilot must show valid BMFA membership. The entrant may change his elected function up to the start of the attempt.

4.1.3.4 Fuel

Composition of fuel is not restricted except for the use of **DIOXINS, TETRANITROMETHANE or NITROBENZINE**, which are prohibited.

4.1.3.5 Control Lines

- (a) All classes except 0.12, F.21, 21N and F.40, may use one or more control wires which may be linked or grouped together provided that control response is not impaired.
- (b) In classes 0.12, F.21, 21N and F.40, only two wire control may be used and no intentional linking or twisting together of the lines is permitted from the point of exit from the model to the control handle.
- (c) Sizes of wire are as shown in Table A with a tolerance of minus 2.5%
- (d) Control wires shall be of uniform diameter piano wire of good quality and in sound condition at least equal to BS 5216.
- (e) Wires bearing marks caused by gripping with pliers or similar shall not be used.
- (f) Wires may not be spliced together.

4.1.3.6 Control Line Connections

- (a) Loop connections on ends of control lines shall be constructed essentially as described and illustrated below.
- (b) Loops shall be bent cold around a suitable circular former (wood dowel, metal rod or similar) whilst the wire is under tension so as to produce a bend of constant minimum radius as shown. The wire must not be heated at any time during the bending process.
- (c) Binding shall be tinned copper wire, minimum diameter 0.2 mm or similar, wound in an open spiral to promote complete penetration of solder to the control line wires.
- (d) Only 'soft' solder shall be used, applied with a suitable flux and using a soldering iron at only sufficient temperature to obtain proper tinning of the wires and adhesion of the solder. Excessive heating must be avoided and soldering by flame heating must NOT be used. Do not use hard solder or silver solder. If the flux used is an acid type, it must be neutralised after soldering with an alkaline solution (baking powder or similar).
- (e) Each side of the soldered area, the binding shall be reinforced by a coating of epoxy adhesive, overbinding with cotton or similar.
- (f) Unsleeved loops shall be attached to models and/or control handles via pins, shafts or 'buttons' with shank diameter sized to fit the loop
- (g) Pins, shafts or 'buttons' (as in (f) above) where attached to any component which will impart any rotary motion to the pin etc. by reason of normal operation of the models controls (e.g. bellcranks, rigid parts of control handles etc.) shall be attached via a concentric axle allowing the pins etc. to rotate freely when the control system is operated under tension equal to the appropriate pull test.

- (h) Sleeved loops shall be protected from deformation by sleeving the wire before bending with brass, copper or aluminium tube or similar of a bore not more than 0.1 mm greater than the control line wire.

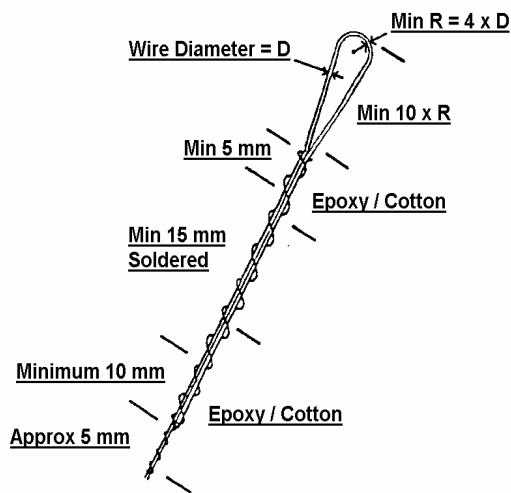

UNSLEEVED LOOP CONNECTIONS

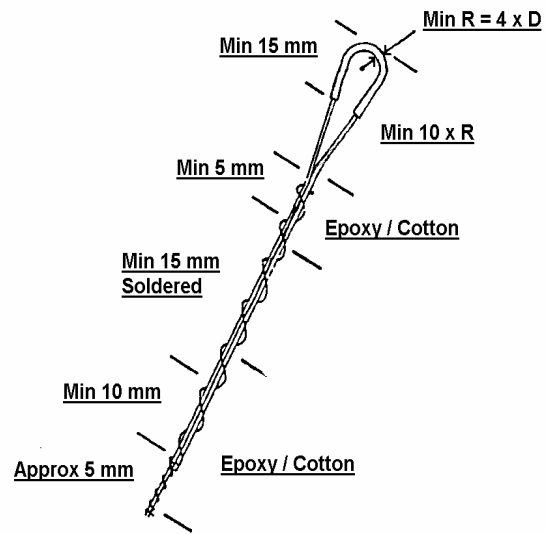

SLEEVED LOOP CONNECTIONS

4.1.3.7 Control Handle

Handles for use with the single point pylon top shall incorporate a 'hook' or other device which, when engaged with the pin on the pylon top, can sustain the entire load generated by the model in flight.

4.1.3.8 Safety Strap

In order to ensure that a speed model is prevented from flying away if inadvertently released by the pilot during a flight a safety strap connecting the competitors wrist to the control handle must be provided by the competitor.

- i) The safety strap must be of the "noose" type, see drawing below
- ii) There is no restriction as to where the strap is connected to the handle, however it is recommended that it is NOT attached at the bottom of the handle grip
- iii) Safety straps may be examined by the Contest Director to ensure that the intent of this rule is met.

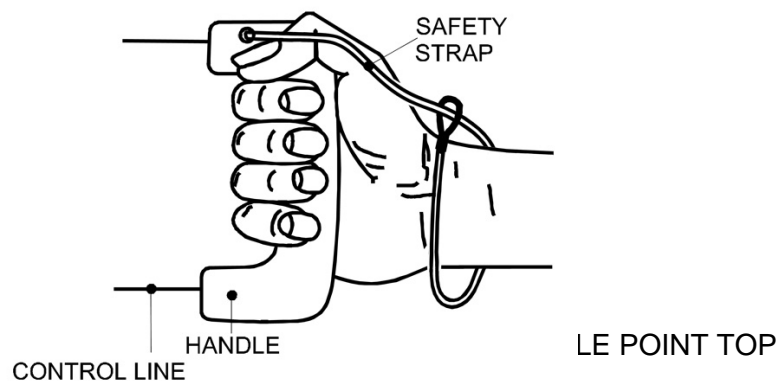

HAND AND SAFETY STRAP FIGURE

4.1.3.9 Pylon Top Details

See drawing.

All dimensions in millimetres.

For FAI Top see FAI Sporting Code.

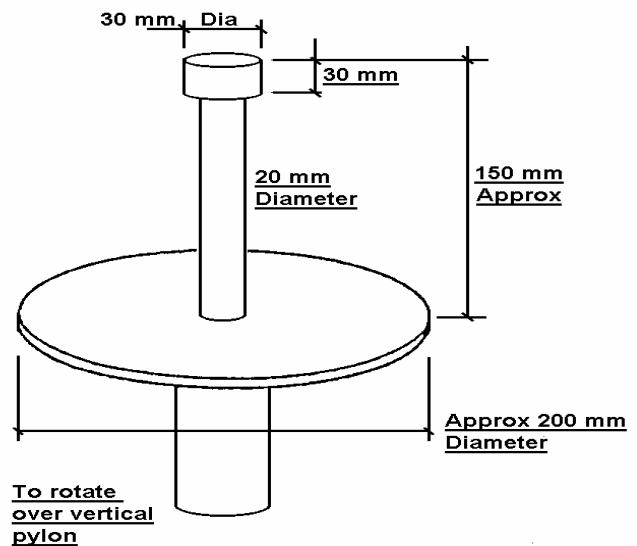

4.1.3.10 Line Tests

- The distance between the centre of the control line handle grip and the axis of the propeller is to be as detailed in Table A, radius of flight.
- If an FAI type of handle is used the distance from the front of the crossbar to the axis of the propeller must be as noted in Table A, radius of flight, plus 6.0 mm.
- If the single point pylon top is used, the distance from the hook or bar to the axis of the propeller must be as Table A, radius of flight, plus 10 mm.
- Where two propellers are employed, the axis of symmetry is taken as the reference for measurement.
- For Jet reaction motors, the centreline of the motor is equivalent to the axis of the propeller.

4.1.3.11 Load Tests

- A load test shall be applied to the assembled control handle, lines and model equal to the load detailed in Table A, pull test.
- In each case the pull shall be applied slowly, increasing to maximum load and releasing at a similar rate.
- The pull test must be applied to the handle grip, not to the point of attachment of the lines and, when the handle is to be used on an a single point pylon top the load test must also be applied to the 'hook' or 'ring'.
- The safety strap/handle assembly must be pulled to the same load as specified in para (a) above.
 - This test may be done separately from the line load test
 - The safety strap does not have to be on the wrist when this test is made
- In the Jet Speed classes, a load test of 22.5 kg shall be applied to the mounting brackets which attach the pulse jet to the model.

Note: For the wrist strap, the Speed Committee recommends a minimum of 80lb capacity cord for classes up to and including 21 and a minimum of 160lb capacity cord for all classes above 21.

Supplies of suitable rope are available from most DIY stores. Parachute cord is available online from Amazon and Dick Hart has a plentiful supply of cord which he is happy to supply foc.

4.1.3.12 Number of Models

A competitor may enter a maximum of two models in each class.

4.1.3.13 Engines

Spares may be fitted to engines during the contest but any individual engine may only be used by one competitor during a contest.

4.1.3.14 Exhaust Systems

- (a) Except for classes 0.12 and 21N, there are no restrictions on exhaust systems.
- (b) For class 21N, the overall length of the exhaust system must not exceed 240 mm measured from the centre line of the cylinder to the furthest point of the exhaust system. This dimension is to be measured along the centreline of the exhaust. The diameter of the exhaust outlet must not exceed 6.5 mm.
- (c) For Class 0.12, either the engine manufacturers expansion type silencer or a Super Silencer may be used. Maximum length of the exhaust system shall not exceed 200 mm measured from the centre line of the cylinder to the extreme end of the tail pipe, along the centre line of the system. Maximum tail pipe diameter shall be 6 mm.

4.1.3.15 Length of Course

The measured distance to be covered by the model must be at least one kilometre for all classes except class (1) 0.049 where the distance to be covered by the model must be at least $\frac{1}{2}$ kilometre.

4.1.3.16 Number of Flights

A competitor is entitled to three flights unless otherwise advertised.

4.1.3.17 Definition of Attempts

A competitor is allowed two attempts per flight, an attempt taking place when:

- (a) The competitor enters the circle, the model flies but the competitor does not engage the pylon with his handle or wrist within the three minutes of being given permission to fly.
- (b) Having engaged the pylon with his handle or wrist, the competitor's model does not complete the timed kilometre.
- (c) The competitor, having engaged the pylon with his handle or wrist, removes the handle or wrist from the pylon without completing the timed kilometre.
- (d) In the opinion of the timekeepers, the model exceeds a height of 4.50 metres during the timed kilometre.
- (e) The model fails to get airborne within three minutes of the competitor being given permission to fly.
- (f) The competitor is judged to have used physical effort to increase the speed of the model after engaging the pylon.
- (g) Jettisoning occurs during the official flight.

4.1.3.18 Timing

- (a) Timing commences when the competitor has engaged the pylon with his handle or wrist and the model has made two complete laps in flight and reaches the marker or the electronic sensor at the end of the second lap.
- (b) The flight time must be taken by two timekeepers equipped with stopwatches recording to 1/100th of a second or with an electronic apparatus approved by the BMFA
- (c) The time recorded is the mean of the two times indicated on the watches or the time recorded by the approved apparatus.
- (d) When using stopwatches for timing and the difference between the two times indicated is greater than 12/100 of a second, the competitor has the right to repeat the flight or to accept the slowest speed.

4.1.3.19 Height of Flight

During the timing of the official flight the flying height must not be less than one metre or more than three metres.

4.1.3.20 Number of Helpers

Each entry is permitted a maximum of three helpers at the starting zone.

4.1.3.21 Team Entries

In addition to individual entries, teams of no more than two people are eligible to compete. No member of such a team may enter the same class in which his team is competing, either as an individual or as a member of another team.

4.1.3.22 Classification

- (a) Unless otherwise announced, all national speed contests will be organised as 'combined speed' events for F2A models as defined in 4.1.(1) and BMFA class models as defined in 4.1.3.2.
- (b) The speed each entrant achieves will be expressed as a percentage of the prevailing national record.
- (c) Contest placing will be determined according to the percentage scored, the highest percentage to win.
- (d) Only the entrant's best single class performance is to count.
- (e) In the case of a tie, the mean of the competitor's two best flights in that single class will be taken to determine the final placings.
- (f) If this still produces a tie, the mean of the competitor's three flights will be taken

4.1.4 SPORT JET SPEED

4.1.4.1 Lines and Controls

Only two line control is allowed.

The line length shall be 17.69 meters and each line shall be a minimum of 0.55mm diameter.

The control system must be mounted external to the normal aircraft contours. The control system includes the bellcrank, lead-outs or control lines, pushrod, and elevator horn.

The lead-out guides may enclose no more than 25mm of the lead-outs or control lines.

4.1.4.2 Engine

The permitted jet engines are the Dyna-Jet, Bailey Sport Jet, OS type II and the Jet Bill Sport Jet. Other engines may be used at the discretion of Contest Director provided that they comply with the intent of the rules below.

Interchanging of parts between the above listed engines is permitted. (Eg use a Dyna-Jet head with a Bailey pipe).

It is required that the engine shall be in stock condition internally. No material may be removed or added to the engine, except as follows:

(a) **Engine Head**

The last three fins on the head may be machined to a diameter of 0.5mm less than the fourth fin in order to locate a mounting strap or ring. Alternatively, holes may be drilled into the head for purposes of engine mounting. The fins on the head of the engine must be exposed. Streamlined fairings ahead of the engine cannot be attached to the head. The valve face may be lapped as needed for routine maintenance.

In engines that have previously had their fins machined off: all or part of the fins may be removed from the head, but the anodizing must be present in the intake throat and the 10 air passages.

(b) **Cowling**

The only engine which is permitted to have a cowling is the OS type II.

(c) **Flowjector**

Fuel feed holes may be drilled out to larger size, or filled and re-drilled but only in their original location.

If a tyre pump is used to start the engine then a short piece of metal tubing may be installed into the tire pump connection to facilitate quick removal of the air supply hose. Alternatively, the threads on the tire pump connection may be filed off or filled in to make a smooth surface to facilitate quick removal of the air supply hose.

(d) **Metering Jet**

Any metering jet may be used, and may be located anywhere between the tank and the flowjector.

(e) **Tailpipe**

A stock pipe must be used. Repaired pipes are permissible, provided that the original stock dimensions are retained. The tailpipe pipe must have at least one point along its length where the maximum cross section area is 806.45 sq mm (1.25 sq in). The front surface of the pipe (combustion chamber screw ring) and the lock ring may be lapped.

(f) **Reed valve**

Any commercially available valve may be used.

4.1.4.3 Fuel

Fuel may be any blend of allowable constituents.

Fuel delivery to the engine shall be by suction; no pressure feed is allowed.

4.1.4. Contest Rules

All other rules shall be as BMFA Class 4.1.3 BMFA Control Line Speed Rules.

4.1.7 F2A and OPEN SPEED LEAGUES

4.1.7.1 Open Speed League For the Johnny Hall Trophy

4.1.7.1.1 General

The open speed league will be run throughout the season.

4.1.7.1.2 Qualifying contests

- (a) All BMFA approved Handicap Speed contests will qualify.
- (b) F2A results are excluded from this league.

4.1.7.1.3 Format

- (a) For each competition, points will be awarded to the percentage scores as follows:

First place	=	ten points
Second place	=	seven points
Third place	=	five points
Fourth place	=	four points
Fifth place	=	three points
Sixth place	=	two points
Seventh place	=	one point
- (b) A league results table will be maintained and updated after each team selection competition.
- (c) At the end of the season, a summation of the best five scores for each competitor will determine the final points for that competitor.
- (d) In the event of a tie, the best individual officially recorded speed will be used to break the tie.
- (e) The competitor with the highest number of points wins the league.

4.1.7.2 F2A Speed League For the Alan Woodrow Trophy

4.1.7.2.1 The competitor with the highest number of points wins the league.

4.1.7.2.2 See 4.0.3.1 F2A Team Selection for the rules for this league.

4.1.5 VINTAGE SPEED **With acknowledgement to SAM 35.**

4.1.5.1 Object

To provide a handicap competition to enable all classes of vintage speed models to compete on an equal basis. Competitors should note the details in BMFA Speed Rules, section 4.1.3 for information on safety and general procedures.

4.1.5.2 Model

- (a) Eligible models are any C/L model which is kitted, or its plan published, before 31st December 1958.
- (b) The structure of the model shall be as near to the original as is practicable.
- (c) Wing area may be increased by up to 30% to increase stability.
- (d) No rescaling of models is allowed apart from (c) above unless shown on the original plan.
- (e) An unscaled kit or plan may be used in more than one class (1-7 only).
- (f) Minor modifications are allowed to enable fitting of alternative engines.

4.1.5.3 Engine

- (a) Any engine produced or in production at 31/12/1958.
- (b) Later derivatives, ie manufacturers developed versions using largely interchangeable components.
- (c) Specifically excluded are engines incorporating technology not commercially available in the model aeroplane world at 31/12/1958.
- (d) Replicas of pre 31/12/58 engines are allowed.
- (e) Where replacement internal parts are not available commercially, it is permitted to substitute equivalent parts from another manufacturer providing it conforms with (c) above.

4.1.5.4 Verification

The competitor must be prepared to produce documentation to verify authenticity of both airframe and engine if so requested by the Contest Director.

4.1.5.5 Propeller

Any wood, thermoplastic or GFRP/carbon propeller may be used & re worked as required. Metal propellers are not permitted.

4.1.5.6 Fuel

Fuel is unrestricted within the limits of BMFA safety rules (see 4.1.3.4).

4.1.5.7 Entrant

- (a) Proxy pilots are permitted.

4.1.5.8 Number of Entries

- (a) Competitors may enter more than one model in any class.
- (b) Only the model with the fastest speed will count for classification purposes.

4.1.5.9 Lines

- (a) Line length and diameter shall be as noted in the table below and will be measured from centre of handgrip to centre of crankshaft of the engine.
- (b) Model, handle and lines shall be pull-tested prior to each attempt in accordance with the table below.
- (c) A safety strap must be worn between handle & wrist.
- (d) Line diameters shown in the table are minima and are single strand piano wire. Multi strand wire may need to be of larger diameter in order to pass the pull test.
- (e) Multi strand wire is not permitted in mono-line classes.
- (f) U-Reely and similar control handles which allow the line length to be varied shall not be allowed.

4.1.5.10 Timing

- (a) The timed distance will be one half mile for all classes.
- (b) Timing will commence two laps after the pilot enters the pylon, or if a pylon is not used, two laps after the pilot's "ready" signal.
- (c) Proto Speed is timed from the moment of release.
- (d) Timing shall normally be with two watches with the average of them being recorded. If times differ by more than 0.2 seconds, the pilot will be offered the option of the slowest time or a re flight.
- (e) Speed (mph) = 1,800/ time in seconds for all classes.

4.1.5.11 Contest Flights

A maximum of three flights per model are allowed, with two attempts per flight. An attempt will be called by the Contest Director when a model fails to become airborne within 5 minutes or if the pilot fails to give a "ready" signal.

4.1.5.12 Whipping

- (a) In the event that a pylon is not available:
- (b) The pilot must walk forward at all times.
- (c) Control handle must be on the pilot's chin or centre of chest.
- (d) Whipping or shortening the flight path in any way, leading the model etc shall result in a "No flight". The flight will be declared void and NO second attempt allowed.
- (e) Proto Speed (Class 8) models may be whipped for one lap only, after which, the handle must be on pilot's chest or chin and the pilot is to be walking forwards.

4.1.5.13 Scoring

Placings will be finalised according to a Handicap System similar to that used in the BMFA Speed Rules, section 4.1.3.2. A list of current highest speeds attained will be held by the Control Line Technical Committee and Contest Directors can contact them via the BMFA Leicester Office.

4.1.5.14 Class Definitions

Class	Capacity		Weight (ozs)	Line Length	Line Diameter (Min) (Note where Imperial & where Metric)			Test Pull (lbs)	N° of Laps
	Cu ins	(cc)			Monoline	2 Line	Swg		
1	0.051	(0.9)	12	35' 0"	0.014"		28	8	12
						0.008"	35	8	12
2	0.10	(1.64)	12	42' 0"	0.014"		28	16	10
						0.008"	35	16	10
3	0.15	(2.50)	16	42' 0"	0.40mm			22	10
						0.010"	33	22	10
4	0.213	(3.5)	16	52' 6"	0.40mm			25	8
						0.010"	33	25	8
5	0.305	(5.0)	24	52' 6"	0.022"		24	45	8
						0.012"	30	45	8
6	0.49	(8.2)	40	60' 0"	0.028"		22	50	7
						0.40m m		50	7
7	0.61	(1.0)	40	60' 0"	0.028"		22	75	7
						0.40m m		75	7
8 Proto	Max 0.305	(5.0)	24	52' 6"	0.022"		24	35	8
						0.012"	30	35	8

4.1.5.15 Record Speeds at 1st January, 2012:

Current records can be seen in the BMFA Records List available

- (i) to read or download from the BMFA website address:
<http://www.bmfa.org/publications/rulebooks/index.html>; or
- (ii) from Sam 35 – call the BMFA office (01162-440028) for contact information or see www.sam35.org.

4.1.6 PROTO SPEED With acknowledgement to SAM 35

4.1.6.1 Model

- (a) Any control line model, kit or plan, resembling a full size aircraft, having a full fuselage, a cockpit or cabin in proportion, a completely cowled engine and a fixed two wheel undercarriage, and published by 31/12/1958.
- (b) The wing area, including the projected area within the fuselage, to be at least 125 sq ins.

4.1.6.2 Engine

The engine capacity is a maximum of 0.305 inc (5.00cm³).

4.1.6.3 Rules

All other rules shall be as BMFA Class 4.1.5. Vintage Speed.

4.1.9 WEATHERMAN SPEED With acknowledgment to SAM 35

4.1.9.1 Model

Cyril Shaw's Weatherman as published by Ian Allen (Model Aviation ~1949). To be built as plan (except classes VI and VII, see below) with no scaling down although wing and tail areas can be increased if desired. Optional; 1¼" diameter spinner, Mandatory; 2 x 2" minimum diameter wheels, bellcrank fastened to hardwood spar built into wing (position optional), undercarriage approximately as plan, external controls. Wing dihedral optional but preferred, but wing and spar must be additionally attached to bearers using screws and/or dowel pins. The tail section should be reinforced and pushrod additionally supported as necessary to prevent vibration in flight.

Classes VI and VII to be built as plan, but scaled up by a factor of 1.414 to give a minimum wingspan of 26.6". Spinner to be 2" diameter.

Class 0 to be built as plan, but scaled down by 25% to provide a minimum wingspan of 14". Spinner to be 1¼" diameter, 1½" diameter wheels and fixed 14swg undercarriage.

4.1.9.2 Engine

Any commercially produced diesel or glow engine may be used except class 1 which is for the Mills 1.3 diesel only, all variants and replicas. No performance enhancing exhaust systems or extensions allowed.

Class	0	Up to 1.0cc
Class	I	Mills 1.3cc diesel only
Class	II	Up to 1.5cc
Class	III	Up to 2.5cc
Class	IV	Up to 3.5cc
Class	V	Up to 5.0cc
Class	VI	Up to 6.6cc
Class	VII	Up to 10.0cc

4.1.9.3 Fuel

Unrestricted within BMFA safety rules

4.1.9.4 Propeller

Any commercially available 2 blade wood, plastic, GFRP/carbon, no metal.

4.1.9.5 Fuel system

Suction only, no pressure from silencer/exhaust or crankcase, no bladders.

4.1.9.6 Silencers

Optional, but no tuned pipes or other devices that increase the power allowed.

4.1.9.7 Timed Distance

Class 0 and I to be ¼ mile from standing start, all others ½ mile from standing start, handle to be on pilots chest by end of first lap. No whipping after 1st lap allowed, otherwise this will result in disqualification.

4.1.9.8 Lines

Only 2 line operation is allowed. Line length and diameter (tolerance $\pm 2.5\%$) shall be as noted in the table below and will be measured from the centre of the handgrip to the centre of engine crankshaft. Model, handle and lines shall be pull tested prior to each flight. A restraining strap attached to the handle is mandatory in all classes. All single strand line ends must be made in accordance with the BMFA handbook, section 4. Line diameters are for single strand carbon spring steel wire. Multi strand may be used, but minimum diameters of 0.3mm ($\pm 2.5\%$, class 0) and 0.4mm ($\pm 2.5\%$, classes II, III and IV) apply. Classes V, VI and VII must use single strand only.

Class Specifications

Class	Capacity (cc)	Max Weight (ozs)	Line Length	Line Dia	Test Pull (lbs)	Laps
0	Up to 1.0	12	35' 0"	0.25mm	15	6
I	Mills 1.3	16	35' 0"	0.3mm	10	6
II	Up to 1.5	16	42' 0"	0.3mm	16	10
III	Up to 2.5	16	46' 8"	0.3mm	25	9
IV	Up to 3.5	20	52' 6"	0.3mm	25	8
V	Up to 5.0	24	52' 6"	0.4mm	35	8
VI	Up to 6.6	32	60' 0"	0.4mm	45	7
VII	Up to 10.0	40	60' 0"	0.4mm	55	7

4.1.9.9 Handles

U-Reely and similar control handles which allow the line length to be varied shall not be allowed.

4.1.9.10 Timing

Ideally there will be 2 watches for timing, the time taken used to be the average of the two. If the difference exceeds 0.2 sec, entrant will be offered choice of the slowest time or a reflight.

4.2.2 BMFA VARIATIONS ON F2B AEROBATICS

Rule numbers refer to the FAI F2B rule number affected.

4.2.(1).4 Line Tests

Add

After the structural integrity test of the handle, lines and model combination has been completed, the following test of the Safety Strap shall be carried out using the values specified in the previous paragraph. Attach the loop part of the Safety Strap, which normally fits over the wrist, to the static load or spring balance, and allow the loop to tighten around the test load or spring balance hook. Apply the load by pulling on the control handle such that the entire test load is reacted through the Safety Strap and its connection to the control handle. If the load is sustained without any failure of the Safety Strap and Control Handle then the test has been successful and the safety strap is satisfactory.

4.2.(1).7 Contest Flights

At BMFA contests the number of flights shall be determined by the Contest Director

4.2.(1).8 Number of Rounds

At the British National Championships, the number of fliers in the fly-off will be limited to 10.

4.2.(1).11 Judging

At BMFA Contests the number of judges shall be determined by the Contest Director.

4.2.(1).12 Classification

Add to sub-section (a), paragraph 2

For final classification of the 15 finalists:

In the event of a tie, a countback system will come into force. The next available score(s) from the finals will be used to break the tie. If this does not produce a result then the qualifying rounds scores (i.e. the highest from each circle) will be used.

If none of the above procedures produces a result then a one round fly-off may be held to break the tie.

4.2.(1).13 Starting Procedure

Add a new paragraph:

The competitor may hand start and warm up his engine within the three minute period, but the engine must be stopped before he gives his official start signal.

4.2.(1).15.16 Four-leaf clover manoeuvre

Replace

- (j) End of manoeuvre: at the end of the last "vertical" climb, as the model aircraft passes through a point above the centre of the circle.

With,

- (j) End of manoeuvre: as the model passes through the 42° point in the vertical climb.

Replace

Recommended exit procedure: continue the Wingover path from the last vertical climb (paragraph (i) above) into a vertical dive, then recover into normal upright level flight at 1.5 metres. Other manoeuvring after completion of the cloverleaf is permitted.

With,

Recommended exit procedure: Continue a line over the pilot's head to the upwind side of the circle, or in windy conditions, to perform a further outside loop section pulling out into level flight at the pilot's discretion. Other manoeuvring after completion of the cloverleaf is permitted.

BMFA VARIATIONS ON THE FAI F2B JUDGES GUIDE

Addition

Should a judge see an incident which could result in cancellation or terminating a flight, he/she should not cease scoring at that point if the flyer continues the schedule. However, the incident and the point at which it occurred should be noted on the score sheet. Thus, in the event of an appeal, a score is available. If the flight is deemed to be terminated or cancelled the relevant part of the score sheet should be struck out.

27 Judges Position 4A.18

If significant changes in wind direction occur, the judges may adjust their position accordingly as they see fit during the flight.

4.2.8 CONTROL LINE TECHNICAL COMMITTEE - AEROBATICS JUDGES TRAINING PROGRAMME

4.2.8.1 Introduction

- (a) The Control Line Technical Committee (CLTC) is committed to providing training for judges for the BMFA Aerobatics Centralised, Team Selection competitions and British National Championships and has instituted an Aerobatics Judges Training Programme that will be run on its behalf by StuntCom, the BMFA Specialist Body for Aerobatics.

4.2.8.2 Outline

- (a) On behalf of the CLTC, StuntCom shall:
 - (i) maintain a list of available judging personnel with their judging credentials;
 - (ii) maintain a list of those personnel attending each judges training seminar;
 - (iii) provide these lists to the CLTC at the end of each year or whenever there are changes to either list;
 - (iv) recommend to the CLTC any names for inclusion on the FAI Judges List (F2B).
- (b) At least one judges training seminar will be held annually unless circumstances beyond the control of the CLTC or Stuntcom prevent this.
- (c) There is a small training budget available for this initiative and travelling expenses will be paid at the end of each year to each person who attended a formal StuntCom training seminar on condition that he was available to, or did, judge as requested by, or on behalf of, the CLTC. Travelling expenses will only be paid on receipt by the CLTC of a properly completed BMFA expenses claim form.
- (d) Each person who attends a training seminar will be issued with a 'Judge's Record Card'. This is a personal record of attendance at seminars and judging at competitions (either solely, in tandem or "shadowing"). It is the individual's responsibility to ensure that the details are properly recorded and the card signed by an official at the seminar or competition.
- (e) Other than for F2B, judges or those applying for judges training do not need to be members of the BMFA.

4.2.8.3 Judging Conditions

- (a) Unless circumstances beyond the control of the CLTC or StuntCom prevented any judges seminars from taking place, judges for any class must have attended at least one judges training seminar each year.
 - (b) When the required number of qualified judges are not be available then experienced fliers may act as judges or an experienced volunteer can be assessed on the day to carry out judging duties.

Any flier acting as such may not compete in that competition and in the case of F2B shall be compensated for giving up an opportunity to gain team selection points in line with rule 4.0.3.2.2 (b).
 - (c) Domestic Judges

Unless competing, the judge shall make himself available to judge at the British National Championships at least once in each two year period.
 - (d) F2B Judges
 - (i) The judge must judge at least one Centralised competition each year.
 - (ii) Unless competing in F2B at the Nationals, the judge must make himself available to judge for the three days of the F2B competition at the British National Championships at least once in every two year period.
- Note**
- (a) In extenuating circumstances the conditions in 4.2.8.3 may be waived by the CLTC.
 - (b) "Available" does not mean that the person has to judge.

- (e) FAI International Judges List
 - (i) Personnel shall be members of the BMFA.
 - (ii) Personnel must be prepared to travel outside the United Kingdom.
 - (iii) Personnel are recommended to the CLTC by StuntCom, the BMFA Specialist Body for Aerobatics.

4.2.8.4 Categories of Judges

F2B (FAI)	Class 2	Vintage
F2B (BMFA)	Classic	

4.2.3 CLASS II AEROBATICS

4.2.3.1 The rules for this contest are based on the FAI class F2B aerobatics rules. Deviations from these rules are listed as follows:

- (a) 4.2.(1).13, change to 'the organisers must appoint a panel of up to three judges approved for their proficiency and experience'.
- (b) Addition - In the event of a crash or premature engine cut, a competitor may (at the judges discretion) re-launch and continue the schedule within the remainder of the 7 minute period.
- (c) A safety strap connecting the competitor's wrist to the control handle must be provided, and used, by the competitor.
- (d) After the structural integrity test of the handle, lines and model combination has been completed, the following test of the Safety Strap shall be carried out using the values specified in Rule 4.2.2 (BMFA Variations on F2B Aerobatics) 4.2.(1).4. Attach the loop part of the Safety Strap, which normally fits over the wrist, to the static load or spring balance, and allow the loop to tighten around the test load or spring balance hook. Apply the load by pulling on the control handle such that the entire test load is reacted through the Safety Strap and its connection to the control handle. If the load is sustained without any failure of the Safety Strap and Control Handle then the test has been successful and the safety strap is satisfactory.

4.2.3.2 List Of Aerobic Manoeuvres

All definitions as in F2B Aerobatics, 4.2.(1).16.

1	Starting.....	K = 1
2	* Take-off, rise off ground with undercarriage - Max 10 points *	K = 2
	* Take off, hand launch - Max 5 points *	K = 2
3	Reverse wing-over	K = 8
4	Three inside loops.....	K = 6
5	Inverted flight (two laps)	K = 2
6	Three outside loops.....	K = 6
7	Two inside square loops	K = 12
8	Two horizontal eights	K = 7

9	Two vertical eights	K = 10
10	Two overhead eights.....	K = 10
11	* Landing, with undercarriage *	K = 5
	* Landing, without Undercarriage *	K = 2

Apart from the exceptions noted * thus *, the 'K' factors for all manoeuvres are as for F2B Aerobatics (4.2.(1).15).

4.2.3.3 Classification of Contestants

- (a) Two categories of contestants are eligible for BMFA Class II Aerobatic contests.
 - (1) Class II contestants who have been designated as such by the BMFA Control Line Technical Committee.
 - (2) Juniors (see 4.2.4, Junior Class II Aerobatics).
- (b) A flyer is transferred out of Class II status when they achieve a level of proficiency determined by their scores in Class II or FAI events. These scores are:

Class II - 480 points	F2B/Open - 700 points
-----------------------	-----------------------

These scores to be equalled or exceeded in four events.

4.2.4 JUNIOR CLASS II AEROBATICS

4.2.4.1 The rules for this class are as for 4.2.3, Class II Aerobatics, except as noted below.

4.2.4.2 Competitors must be under 18 years of age on 1st January of the year of the contest.

4.2.4.3 A handicap system will operate allowing a 10% bonus increase to a juniors flight score if under 14 years of age on 1st January of the year of the contest.

4.2.4.4 A junior (as defined in 4.2.4.2) may enter a Junior Class II Aerobatics event in his own right as a junior irrespective of having exceeded the transfer score (as defined in 4.2.3.3.(b)). Qualifying scores may be accrued by the competitor for use at 18 years

4.2.5 VINTAGE STUNT

With Thanks to SAM 35

4.2.5.1 Objective

- (a) To provide a standard set of rules for use in competitions for control line stunt models designed during the period when this class of model was being developed.
- (b) The schedule of manoeuvres is based on the schedule(s) that were in use during this period both in the USA and in the UK These manoeuvres were chosen to allow the pilot to demonstrate the model's ability without over-stretching the ability of a reasonably competent C/L stunt flyer.

4.2.5.2 Aircraft

- (a) Design must have been available in kit or plan form prior to 31st December 1952. Exceptions to this rule may be permitted as follows:
 - (1) Where evidence of the existence of the kit or plan prototype before 31st December 1952 is available (e.g. a magazine photograph published prior to 31st December 1952).
 - (2) Where only photographic evidence of a design was published before 31st December 1952 but the original designer can provide accurate details of the model's design.
- (b) No modifications shall be permitted other than structural changes to strengthen the aircraft and changes to the leadout position and/or tipweight as trimming aids.
- (c) Any modifications which, in the opinion of the judges, significantly change the appearance and/or the performance of the aircraft as originally designed shall not be allowed.
- (d) A list of eligible models is held at the BMFA's Leicester office and is available on request.

4.2.5.3 General

- (a) Line tests are as Rule 4.2.2 (BMFA Variations on F2B Aerobatics) Rule 4.2.(1)4.
A safety strap connecting the competitor's wrist to the control handle must be provided, and used, by the competitor.
- (c) After the structural integrity test of the handle, lines and model combination has been completed, the following test of the Safety Strap shall be carried out using the values specified in Rule 4.2.2 (BMFA Variations on F2B Aerobatics) 4.2.(1).4. Attach the loop part of the Safety Strap, which normally fits over the wrist, to the static load or spring balance, and allow the loop to tighten around the test load or spring balance hook. Apply the load by pulling on the control handle such that the entire test load is reacted through the Safety Strap and its connection to the control handle. If the load is sustained without any failure of the Safety Strap and Control Handle then the test has been successful and the safety strap is satisfactory.
- (d) The contest will consist of two official flights, the resulting score to be the total of these flights. At the discretion of the CD the contest may consist of three flights where the highest two scores will be totalled but this must be notified to the competitors prior to the start of the contest.
- (e) The contestant is allowed two attempts at each official flight. An official flight begins when the contestant signals the next manoeuvre after level flight.
- (f) All manoeuvres must be signalled before they are started by the raising of the free hand for at least half a lap.
- (g) Manoeuvres are to be performed in accordance with the attached schedule.
- (h) All current BMFA safety rules (pull test, line diameter etc.) shall be applied with the exception of rule 4.0.1.4.
- (i) No appearance points shall be awarded.
- (j) In order to enable older and smaller designs to be competitive, bonus points as stated below will be awarded:
 - (1) A bonus of 15 points for a design up to 31st December 1947.
 - (2) A bonus of 12 points for a design up to 31st December 1948.

- (3) A bonus of 9 points for a design up to 31st December 1949.
- (4) A bonus of 6 points for a design up to 31st December 1950.
- (5) A bonus of 3 points for a design up to 31st Dec 1951.
- (6) A bonus of 30 points for the use of an engine running on spark ignition.
- (7) A bonus of 20 points for an aircraft which does not include wing flaps.
- (8) A bonus of 10 points for the use of a biplane.
- (9) A bonus of 5 points for an engine of 3.5 cc or less.
- (10) A bonus of 10 points for an engine of 2.5 cc or less.
- (11) A bonus of 20 points for an engine of 1.5 cc or less.
- (12) A bonus of 25 points for successfully completing the schedule in the correct order.

Note 1

To qualify for the bonus points shown in section (j) the contestant must satisfy the judges that the model meets the criteria or the relevant bonus points will not be awarded.

Note 2

Bonus points are only to be awarded after an official flight has been made.

Note 3

Full bonuses will only be applied to models which match original plans, subject to 4.2.5.2.(b). Modern technical 'performance improvers' forfeit half the score on affected figures, i.e. tall tailwheels (take-off and landing points).

- (k) Silencers should be used whenever possible. Local silencer rules MUST be obeyed.
- (l) Pressurised fuel systems are permissible.
- (m) Scaling up or down of designs is not permitted.
- (n) Aircraft designs that did not include a fixed undercarriage may be fitted with an undercarriage of the two wheel, tail dragger type.
- (o) Models that do not have an undercarriage may be entered. In this case, 'take-off' will be judged on the smoothness of the fly away from hand launch. Landings will be judged on smoothness of approach.
- (p) Each entrant will be given a slot of 10 minutes to complete the schedule.

Some smaller model designs were such that the largest fuel tank size that could be installed was insufficient to complete the full schedule of manoeuvres. In this case the contestant may land, refuel, restart and relaunch the model. When this is to be done, the contestant will inform the judge(s) as to which point in the schedule the flight will be broken. The first start and take-off and the last landing will be judged. In the event of failure to restart, the one landing will be scored.

- (q) Aircraft designs that were originally fitted with operating wing flaps must have operating wing flaps. Fixing the wing flaps constitutes a design modification and is not permitted under 4.2.5.2.(b).

4.2.5.4 Vintage Stunt Schedule

- (a) A minimum of 2 laps level flight must separate each manoeuvre.
- (b) All hand signals must be clearly given.
- (c) The bonus points for the completion of the schedule will be awarded if all manoeuvres are attempted. If for instance only 4 loops are flown, the manoeuvre has been attempted and will be marked.

- (d) The points spread to be awarded by the judges for each manoeuvre will be as noted on the vintage stunt score sheet.
- (e) The contestant may attempt a manoeuvre only once in any flight. The contestant must complete the flight programme within 10 minutes including the take off and landing and any re-fuelling stops. The 10 minute time limit commences when the contestant gives a hand signal prior to starting the engine.

1 Take-off within one minute

5 points

The time allowed to obtain 5 points for getting the model airborne within 1 minute starts when the contestant or helper signals that he is ready to start. The contestant has a total of 3 minutes to get the plane into the air from the time the handle is placed in the centre of the flight circle. Failure to become airborne within the 3 minute limit will constitute an attempt. The engine must be started by the contestant. The use of a starter is permitted.

2 Take-Off

Maximum - 5 points

Upon release the model must be seen to roll forward under proper control and rise smoothly to level flight within one lap. If hand launched, the model must be seen to be under control after release and to rise smoothly as with ROG.

3 Level Flight

2 laps at 6 feet altitude - maximum 5 points

Starting one lap from release the model flies at a constant altitude between 6 and 10 feet (1.8 to 3 metres). No signal from the pilot is required.

4 Vertical Climb

Maximum - 10 points

The model climbs vertically for a minimum of 15 feet (4.6 Metres) and returns to a horizontal attitude before reaching a point directly over the pilot.

5 Vertical Dive

Maximum - 10 points

The model enters a vertical dive from a level below the overhead point, dives for a minimum of 15 feet (4.6 metres) and then pulls out into level flight.

6 Wing Over

Maximum - 15 points

The wing over starts from level flight and climbs vertically, passing directly over the pilot, down the other side of the circle and pulling out into level flight again, cutting the circle in half.

7 Five Consecutive Inside Loops

1st loop maximum - 10 points

2nd to 5th loops inclusive maximum- 5 points each

Total maximum - 30 points

Inside loops are entered and exited from level flight. The line angle must not exceed 60° and all loops are to be circular and superimposed

8 Five Consecutive Outside Loops

1st loop maximum - 10 points

2nd to 5th loops inclusive maximum- 5 points each

Total maximum - 30 points

These may be entered from a 60° line angle or from inverted level flight after a 'flip-over'. The other conditions are as for inside loops.

9 Two Laps Inverted Flight

Maximum - 30 points

Entry is an inside or outside 'flip-over'. The two scored laps begin at the end of the 'flip-over'. Recovery, part of an outside loop, begins EXACTLY two laps later. Both entry and exit manoeuvres are marked as part of the whole manoeuvre.

10 Three Horizontal Figure Eights

1st eight maximum - 20 points

2nd and 3rd eights maximum - 10 points each

Total maximum - 40 points

The loops of the horizontal eights must not exceed a line angle of 60°. Each loop must be circular, the intersection vertical and superimposed. The manoeuvre must be entered and exited via the inside loop which is to the left of the pilot.

11 Three Vertical Figure Eights

1st eight maximum - 20 points

2nd and 3rd eights maximum - 10 points each

Total maximum - 40 points

This is a vertical version of the horizontal eight with the entry into the bottom inside half loop followed by an outside top loop with a maximum line angle at the top of 90°. The exit is out of the inside loop into level flight. The intersections must be horizontal.

12 Three Overhead Figure Eights

1st eight maximum - 20 points

2nd and 3rd eights maximum - 10 points each

Total maximum - 40 points

This is the overhead version of the above eights with the entry and exit at 30° line angle at the bottom of the inside loop, to the left of the pilot. The intersections must be overhead and must split the circle in half.

13 Square Loop

Maximum - 40 points.

This is a square inside loop with the horizontal portion covering at least 1/4 lap. The corners should have a radius of approximately 5 feet (1.5 metres). The top of the loop must not exceed 60° line angle. Entry and exit is level flight.

14 **3 Leaf Clover**

Maximum - 40 points

The manoeuvre consists of a single horizontal '8' stretched over approximately half a lap. At the intersection point the model will be travelling downwards, after the outside loop, at an angle of about 30°. At the point of intersection an inside loop is performed to a maximum line angle of 75°. The manoeuvre is completed when the intersection point has been passed and the model returns to level flight.

15 **Landing**

Maximum - 15 points

When the engine stops the model is to make a smooth approach to ground level where it will make contact gently. Models with an undercarriage will roll forward and come to a standstill in an upright position, without bouncing. Those without an undercarriage will slide along for a short distance and settle in an upright position.

Nose over - 1 Rough - 5 Bounce - 10 Smooth - 15

Special points to remember: Contestants may fly as many laps as desired for warming up and testing. When ready to start the flight pattern, a raised arm signal must be given to the judges. It is up to the contestant to give this signal long enough to ensure that the judges have seen it. Holding the signal during the entire level flight manoeuvre is suggested. There must be at least two level laps between manoeuvres. If your model flies fast, it is suggested that you do several laps between manoeuvres in order to give the judge time to complete his scoring.

4.2.5.6 **Rules Interpretation**

- 1 Starting: The one minute time starts on the signal from the flyer. Electric starters are allowed.
- 2 Take-Off: A smooth take-off requires 'some' rolling distance and ROG without sudden pitch changes. A correctly working drop-off undercarriage is acceptable if originally shown on the plan.
- 3, 4, 5 and 6. Level flight is 6 feet altitude.
- 7 and 8, Inside and Outside Loops: 60° altitude is ideal. Smaller loops are downgraded. Outsides are entered from upright start and end at 60°. Bottom of all loops should be at 6 feet altitude.
- 9 Inverted: Entry is an inside or outside 'flip-over'. The two scored laps begin at the end of the 'flip-over'. Recovery is a part outside loop and it begins exactly two laps later.
- 10 Horizontal Eights: are 'lazy eights' i.e. the inside loop is past the intersection, bottoms at 6 feet, tops at 60°, and a vertical dive at the intersection is required.
- 11 Vertical Eights: A 6 feet entry gives a 'lazy eight', half inside loop to 45° altitude then high outside loop back to 45° followed by second half of inside loop to 6 feet.
- 12 Overhead Eights: lazy eight, enter the first half loop at 30°, recover at entry point. Think about your stance!
- 13 Square Loop: Must be 60° high and 90° wide. The top is 1/4 lap inverted at 60° altitude. To the flyer it looks as if it sags in the middle..
- 14 Landing: If a drop-off undercarriage is fitted, see 4.2.5.6.2 above, landing points will be awarded as for models with no undercarriage, i.e.
Nose over - 1 point rough - 5 points bounce - 10 points smooth 15 points

Vintage Stunt Manoeuvre Diagrams

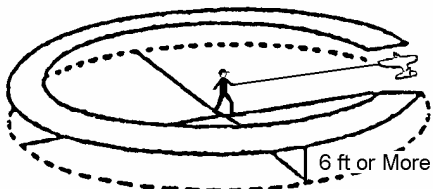

3. Level Flight

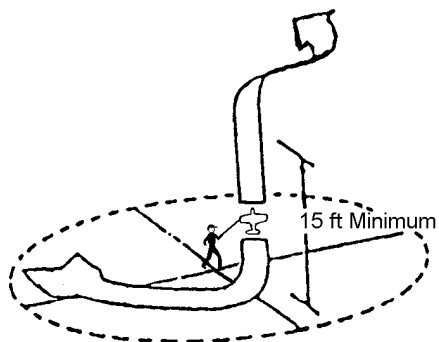

4. Vertical Climb

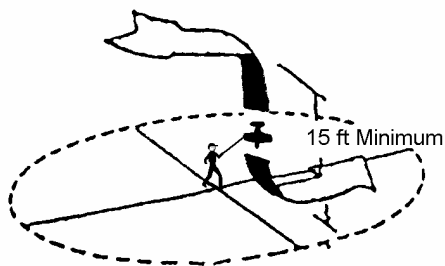

5. Vertical Dive

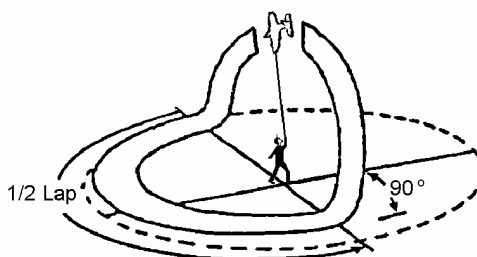

6. Wing Over

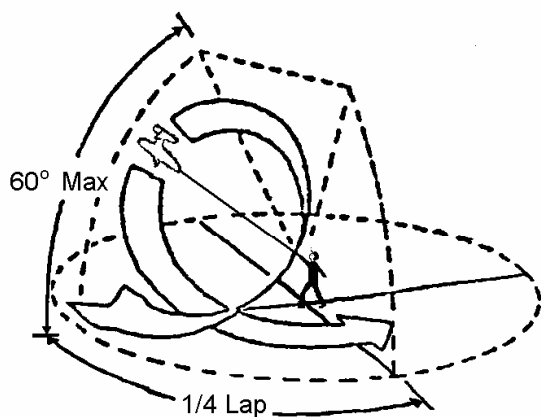

7. Inside Loops

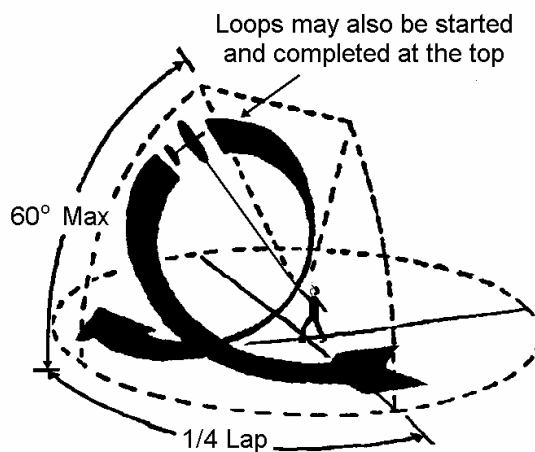

8. Outside Loops

Vintage Stunt Manoeuvre Diagrams (Continued)

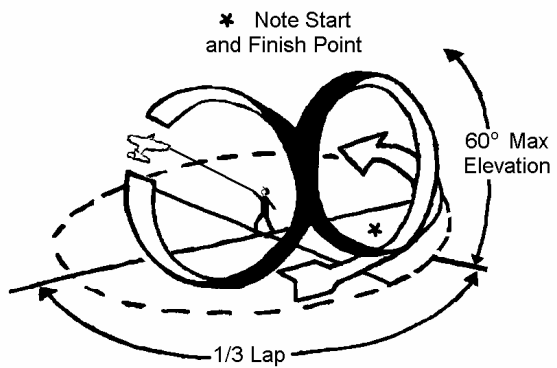

10. Horizontal Eight

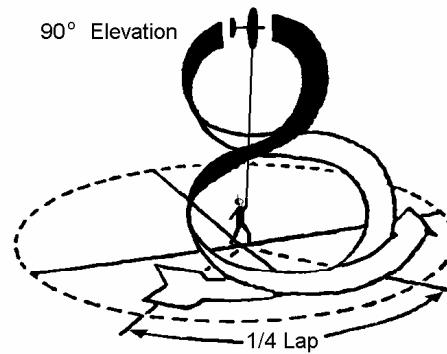

11. Vertical Eight

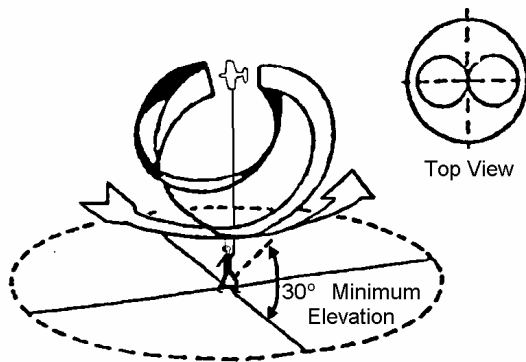

12. Overhead Eight

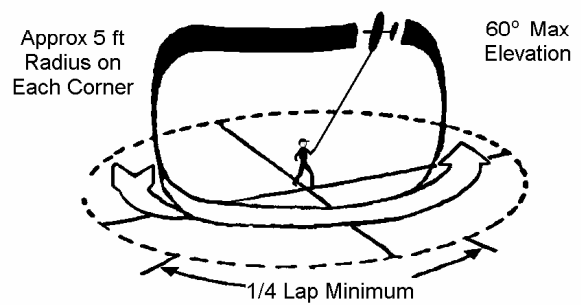

13. Square Loop

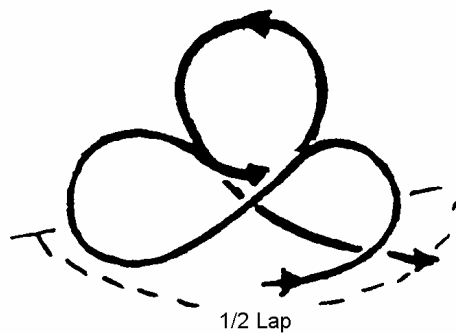

14. Three Leaf Clover

5.2.5.7 VINTAGE STUNT SCORE SHEET

NAME	DRAW NUMBER				
	POOR	FAIR	GOOD	EXCEL	SCORE
TAKE OFF WITHIN ONE MINUTE					5
TAKE OFF	1	3	4	5	
LEVEL FLIGHT (2 LAPS)	1	3	4	5	
CLIMB	3	5	7	10	
DIVE	3	5	7	10	
WINGOVER (1)	3	8	12	15	
INSIDE LOOPS (5)	5	10	20	30	
OUTSIDE LOOPS (5)	5	10	20	30	
INVERTED FLIGHT (2 LAPS)	5	10	20	30	
HORIZONTAL EIGHTS (3)	10	20	30	40	
VERTICAL EIGHTS (3)	10	20	30	40	
OVERHEAD EIGHTS (3)	10	20	30	40	
SQUARE LOOP (1)	10	20	30	40	
3 LEAF CLOVER (1)	10	20	30	40	
LANDING	1	5	10	15	
BONUS POINTS FOR:					
COMPLETED SCHEDULE IN ORDER					25
DESIGN BEFORE 31st DECEMBER	1947	1948	1949	1950	1951
SCORES	15	12	9	6	3
NO FLAPS					20
SPARK IGNITION					30
BIPLANE					10
MOTOR CAPACITY UP TO OR INC.	1.5 cc	2.5 cc	3.5 cc		
SCORES	20	10	5		
JUDGED BY				TOTAL	
DURATION OF FLIGHT (Max 10 MINUTES)					

4.2.6 CLASSIC AEROBATICS

4.2.6.1 Model

- (a) Eligible models must have been available in kit or plan form prior to 31st December 1969. Exceptions to this rule may be permitted as follows:
 - (1) Where evidence of the existence of the kit or plan prototype before 31st December 1969 is available. (e.g. a magazine photograph published before that date).
 - (2) Where only photographic evidence of a design was published before 31st December 1969 but the original designer has or can provide accurate details of the model's design.
- (b) No modifications shall be permitted other than structural changes to strengthen aircraft.
- (c) Any modifications which, in the opinion of the judges, significantly change the appearance and/or performance of the aircraft as originally designed shall not be allowed.

Note: A list of eligible models is available from the BMFA office.

4.2.6.2 Flying Schedule

The flying schedule will be as is currently used for F2B Aerobatics.

4.2.6.3 Scoring

Scoring will be as for F2B with the exception of 4.2.6.4.

4.2.6.4 Appearance Points

- (a) Models will be awarded appearance points out of 10 by each judge. These marks will be decided before the competitors first flight score sheets are handed to the Contest Director and will be noted on those score sheets.
- (b) A 'K' factor of 5 will be applied to these marks and the total arrived at shall be added to the competitor's highest flight score of the contest.

4.2.6.5 Safety Strap

A safety strap connecting the competitor's wrist to the control handle must be provided, and used, by the competitor.

After the structural integrity test of the handle, lines and model combination has been completed, the following test of the Safety Strap shall be carried out using the values specified in Rule 4.2.2 (BMFA Variations on F2B Aerobatics) 4.2.(1).4. Attach the loop part of the Safety Strap, which normally fits over the wrist, to the static load or spring balance, and allow the loop to tighten around the test load or spring balance hook. Apply the load by pulling on the control handle such that the entire test load is reacted through the Safety Strap and its connection to the control handle. If the load is sustained without any failure of the Safety Strap and Control Handle then the test has been successful and the safety strap is satisfactory.

4.2.6.6 All other rules shall be as for F2B Aerobatics.

4.2.7 GOLD TROPHY AEROBATICS

4.2.7.1 General

- (a) The rules for this contest are based on the FAI class F2B aerobatics rules.
- (b) The event will be run on a rounds basis where the final classification is determined by the scores attained by the competitors in the rounds.
- (c) A safety strap connecting the competitor's wrist to the control handle must be provided, and used, by the competitor.
- (d) After the structural integrity test of the handle, lines and model combination has been completed, the following test of the Safety Strap shall be carried out using the values specified in Rule 4.2.(1) 4.. Attach the loop part of the Safety Strap, which normally fits over the wrist, to the static load or spring balance, and allow the loop to tighten around the test load or spring balance hook. Apply the load by pulling on the control handle such that the entire test load is reacted through the Safety Strap and its connection to the control handle. If the load is sustained without any failure of the Safety Strap and Control Handle then the test has been successful and the safety strap is satisfactory.

4.2.7.2 Definition

A round is one flight in each of the two judged circles.

4.2.7.3 Number of Flights

- (a) Each competitor is entitled to an equal number of flights in each judged circle.
- (b) The total number of rounds, therefore flights, is determined by the CD.
- (c) Only complete rounds will count towards final classification.
- (d) In the event of a round being stopped due to an 'Act of God' (such as a heavy thunderstorm), the whole round will be cancelled if, in the CD's opinion, time does not allow for it to be resumed and finished.

4.2.7.4 Final Classification

- (a) If the contest consists of three rounds, then the lowest flight score in each judged circle will be discarded and the remaining flights will count towards final classification.
- (b) If the contest consists of two rounds, then both flights in each judged circle will count towards final classification.
- (c) If the contest consists of only one round, then each flight in each judged circle will count towards final classification.
- (d) In the case of a tie for any position, the highest single flight score of the competition in the same judged circle shall decide the tie.

4.2.7.5 Other Rules

All other rules for the event will be as 4.2.(1), FAI F2B Aerobatics.

4.3.2 BMFA VARIATIONS ON F2C

In BMFA contests, the following variations shall apply to class 4.3.(1) F2C Team Race as noted. The rule numbers refer to the F2C rule number affected.

- 4.3.(1).1.(d)** If there are insufficient entries to warrant the running of the semi-final rounds, the Contest Director may place the fastest three teams from the heats directly into the final.
- 4.3.(1).2.** The circle marking shall be a minimum of the flight circle at 19.6m radius, the centre circle at 3m radius and the inner circle at 2m radius.
- 4.3.(1).7.(a)** A minimum of one timekeeper and a maximum of three timekeepers will be assigned to each team.
- 4.3.(1).9.(k)** A team shall be disqualified if the mechanic reaches more than 0.5m into the flight circle, as judged by the Contest Director.
- 4.3.(1).12.(a)** At BMFA centralised competitions, designated team selection competitions and the British National Championships, a minimum of one Contest Director may conduct racing, and act as the team race panel of judges.
- 4.3.(1).13.(b)** Coloured panels may replace lights for notifying warnings to teams.

Annex E, Appendix 11 The circle marking shall be a minimum of the flight circle at 19.6m radius, the centre circle at 3m radius and the inner circle at 2m radius.

4.3.4 GENERAL TEAM RACING RULES

4.3.4.1 Definition of Team Racing

- (a) A team racing event is a contest in which qualifying races (heats) are followed by semi-finals races and a final race. Three model aircraft participate simultaneously in each race, flying in the same circle, each of them being entered by one team. In exceptional cases a race may be run with only one or two teams.
- (b) Races for heats, semi-finals and finals shall be run over a set number of laps with at least one landing for refuelling in a heat and one in a final. Both the number of laps and the refuelling landings are as specified in the individual class rules.
- (c) A team shall consist of a 'pilot' who shall remain in the centre of the circle, piloting the model, and one mechanic who shall remain outside the circle and who shall catch or recover the model, refuel, start the engine(s) and perform any other necessary duties throughout the race. Where the class rules permit, one assistant may help the pitman.

- (d) The entrant shall be the team.
 - (i) The personnel of a team shall remain unaltered throughout a race.
 - (ii) Personnel may change teams between races and they may compete in multiple teams during an event.
 - (iii) At the British National Championships personnel may only enter in one team in each class flown.
- (e) Engines must be started by hand, mechanical starters are not permitted.
- (f) During the race the mechanic and his assistant shall each wear a suitable safety helmet retained by a securely fastened chin strap.

4.3.4.2 Team Racing Site

- (a) The flight circle is divided into six equal segments for the location of the pitting areas of the teams.
- (b) Concentric circles to be used by the pilots and mechanics shall be marked on the flying area in accordance with the individual class rules.

4.3.4.3 Definition of a Team Racing Model Aircraft

Model aircraft in which the propulsion energy is provided by a piston engine(s) and in which lift is obtained by aerodynamic forces acting on the supporting surfaces which except for control surfaces must remain fixed in flight. The model aircraft must be of a semi-scale type and its general lines must be similar to those of a full-size aircraft.

4.3.4.4 Characteristics of a Team Racing Model Aircraft

- (a) All models shall fly counter clockwise.
- (b) Model aircraft must rise off the ground.
- (c) The undercarriage must be a permanent fixture on the model to permit take off and landing. The undercarriage may retract in flight, but it must return to its correct position before landing.
- (d) The use of all-metal wheels is forbidden.
- (e) Nose skids are permitted, provided that no part of the skid is in front of the point of exit of the skid from the model. The free end of the skid shall point backwards.
- (f) The BMFA number of one of the team members shall be displayed on the wing in numerals at least 25 mm high.
- (g) All models shall carry a marking on the inboard wing tip in numerals 20 mm high showing the weight of the model in grams. The weight shall include a full tank of fuel but not the lines. A tolerance of plus or minus 30 grams of the true weight is permitted.
- (h) Unless otherwise specified in the class rules, the model aircraft must be equipped with an effective engine-stopping device to enable the pilot to terminate the engine run before the fuel tank is completely empty.
- (i) The model must remain in the same condition throughout the race; no jettisoning of parts is permitted.
- (j) The measured fuel tank capacity includes the feed pipe plus any filler valve and/or shutoff device.
- (k) Detailed characteristics of models for each class are defined in the individual class rules.

4.3.4.5 Controls

- (a) Only two line control is permitted.
- (b) Line lengths and diameters shall be as specified in the individual class rules.
- (c) A load sufficient to remove only the slack from the lines shall be applied during the line length check.
- (d) A load check as specified in the individual class rules shall be applied to the control system (handle, wires and bell crank) for a period of 10 seconds.
After the load test the control system shall be checked for correct operation.
- (e) Intentional twisting and/or linking of the two lines together is not permitted between the point of exit of the model aircraft and a point 300 mm from the handle.
- (f) The use of flexible grouper(s) attached to the wing tip and extending a maximum of 20 mm is permitted.

4.3.4.6 Number of Models

- (a) A team may enter a maximum of two models in each class at a contest. Only one model may be used in any heat.
- (b) A team may interchange parts between the two models provided that the resulting model still fits the specification for that class and is re-checked by the Contest Director.
- (c) A model or any part of that model may not be used by more than one team at a contest.
- (d) Spare propellers, glow plugs, and general accessories are permitted.

4.3.4.7 Engines

- (a) There is no limit on the number of engines a team may use during a contest. An engine may only be used by one team during a contest.
- (b) The use of T bar compression adjustment screws or compression adjustment screws which have a forward facing projection with cross section area of less than 8 mm² is not permitted.
- (c) All engines must be fitted with a spinner or safety nut Needle nosed spinners are not permitted.

4.3.4.8 Race Organisation

- (a) Three competing teams (in exceptions only two, or one) will fly simultaneously in each race after having been drawn for order. Qualifying races with fewer than 3 teams will be put at the end of the draw, to enable three-team races, by including teams who have been granted reflights.
- (b) The allocation of starting positions will be by random draw. The competitor drawn first will have the choice of starting positions. The remaining competitors will, in order of the draw, select one of the remaining unoccupied starting segments.
- (c) If the race draw, or withdrawals therefrom, results in a single team remaining for a race, teams who have already flown may volunteer to make up a complete race complement. Any time which they then record may be used in the final classification. If there are no volunteers, the team will be allowed to fly alone to complete its qualifying reflight during the same round.

- (d) Just before entering the circle, teams may be allowed to run their engines only under the organiser's supervision so that the engine running does not interfere with the starting procedure of a race. Mechanics are not allowed to walk with a running engine.
- (e) Each team occupies one pitting area. Teams will select pitting areas in the order of the draw; the first drawn team has first choice. The other teams choose one of the remaining free pitting areas in order of the draw. The chosen pitting areas are considered occupied until the race is finished.
- (f) For the final race, the choice of the pitting areas shall be determined by the results in the semi-finals. The team with the fastest time chooses first, the team with the second fastest time chooses next, etc. In case of a tie in the semi-finals, the teams' second fastest times will decide the order of choice.
- (g) After entry to the circle and unless allowed by the Circle-Marshal, it is forbidden to start an engine before the first signal has been given by the Circle Marshal.
- (h) Models must fly at a normal height of two to three metres except when overtaking, taking off or landing. See also rule 4.3.4.11.
- (i) The landing model has priority.
- (j) If only one team remains in participation before the half distance point of the race has been reached, the race will be declared null and void. That team will then be awarded a reflight which shall be flown at the end of that same round.

4.3.4.9 Race Procedure

- (a) Up to three timekeepers will be assigned to each team. They will stand outside the flight circle, near the pitting area of the model aircraft that they are assigned to time. They are in charge of the timekeeping and lap counting for their particular team.
- (b) A first signal gives the mechanic the opportunity to run his engine(s) during a sixty second period unless specified otherwise in the individual class rules.
- (c) A second signal announces the end of that warming up period, and engines must be stopped.
- (d) Thirty seconds are then allowed during which last-minute preparations may be made. The starter counts the last five seconds during which the pilot must be crouching, the mechanic must be standing at the 3 second point and not touching the model which must be on the ground.
- (e) The starting signal is given by means of both a visual signal (flag) and an acoustic signal (whistle/horn). A PA system may be used.

4.3.4.10 Refuelling

- (a) See rule 4.3.4.1.(b).
- (b) The model must not be recovered with the engine running or prior to touchdown with the engine stopped. See rule 4.3.4.15 (d).(viii).
- (c) The mechanic must refuel his model at his allocated pit segment. If the model stops away from his segment, he must move to the nearest unoccupied segment rearwards of the stopping point of the model.
- (d) Only when this pitting area is already occupied by another competitor, may he occupy the pitting area forward of the stopping point.

- (e) In the case of a model stopping in a sector where the adjacent pitting areas are already occupied, the mechanic must go backward to the nearest free pitting area.
- (f) During refuelling and restarting, the model must remain in contact with the ground, lines and control handle must remain close to the ground as defined by the CD.
- (g) After the mechanic has caught the model, but only then, is the pilot allowed to put one foot outside the pilots' circle.

4.3.4.11 Altitude of Flight and Overtaking

Racing height shall not exceed 3 metres, and the height of overtaking models shall not exceed 6 metres. In overtaking, the faster model must pass over the top of the slower unless forced by exceptional circumstances to do otherwise.

4.3.4.12 Race Format

- (a) The competition shall be divided into a maximum of three qualifying rounds and, two rounds of semi-finals and a final. Each team shall be given the opportunity to fly in each of the qualifying rounds.
- (b) It is not permissible for any person to be a member of more than one team in a final. See also rule 4.3.4.1.(d).
- (c) The number of teams qualifying for the semi-finals will depend on the total number of teams entered in the competition. Each qualifying team may take part in two semi-final races.

Number of teams	number of semi-finalists
2 up to and including 8	0
9 up to and including 11	6
10 up to and including 39	9
40 or greater	12

- (d) In the case of a tie for the semi-finals, the second qualifying round result will decide the teams.
- (e) The three teams which have recorded the three fastest times in either round of the semi-finals will qualify for the final.
- (f) If there is insufficient time to run the semi-final rounds, the Contest Director may, at his discretion, place the fastest three teams from the heats directly into the final.
- (g) In the event of a tie in the final, the two teams must have a fly-off over the same distance to decide the placing.
- (h) If, through interference or obstruction, a team is forced to retire from a race through no fault of its own, it shall be given the opportunity of a further attempt.
- (i) The race time of each team is decided from the moment of the starting signal to the moment of completion of the final lap of the specified race distance.

4.3.4.13 Finish of the Race

The race shall have ended when the competitors' models have completed the required distance, or the maximum time as defined in the individual class rules, has elapsed.

4.3.4.14 Classification

The final placing of the first three teams is established solely on the results of flights in the final. The remaining teams are placed according to their best flight time in the semi-finals, if they qualified for those races, or in the qualifying rounds.

4.3.4.15 Warnings and Disqualifications

(a) Warnings may only be given by the Contest Director. Warnings must be given both verbally, with at least a megaphone (or similar PA system), and visually. Warnings are given to the team.

(b) Any team receiving three warnings shall be disqualified from that race.

(c) A Team Shall Be Warned

If:

(i) A pilot interferes with, or obstructs, another pilot either by his conduct in the circle or by a manoeuvre of his model which prevents another model from flying or landing normally.

(ii) A pilot stands in the centre, or walks backwards, instead of walking around the centre.

(iii) The pilot applies physical effort to increase the speed of his model during the official flight.

(iv) The height of the flight prescribed by the rules is exceeded.

(v) During either the start of the race or the pit stops, the pilot does not keep one hand on the ground and the handle and lines close to the ground as defined by the Contest Director.

(vi) The mechanic is not standing upright, or moves, prior to the starting signal.

(vii) For any other flagrant breach of the rules.

(d) A Team Shall Be Disqualified From a Race

If:

(i) The pilot steps out of the 3 metre pilots' circle before the mechanic has taken hold of the model.

(ii) The mechanic or assistant steps into the flight circle with both feet.

(iii) The model is retrieved from inside the flight circle by means of any device.

(iv) Under normal flying conditions, overtaking is done by passing under the slower model.

(v) The pilot whose model is to be overtaken carries out any manoeuvre to impede the overtaking competitor.

(vi) Either member of the team causes a collision between the models.

(vii) Jettisoning occurs.

(viii) The model is recovered with either the engine running or with the engine stopped but prior to touchdown.

(ix) For any other flagrant breach of the rules.

4.3.5 SEMI SCALE CLASS RULES

4.3.5.1 CLASSES 1/2A, "B" AND BARTON B

- (a) The engine(s) must be enclosed. External additions and modifications to the engine shall be permitted to be exposed as long as they conform to the natural shape of the fuselage and do not mar the semi scale appearance of the model.
- (b) The only parts permitted to protrude from the body are the muffler system(s), if carried, and parts which have to be manipulated during the operation of starting or adjusting the engine(s); i.e. fuel needle valves, compression controls, plugs, tank fillers, etc.
- (c) Openings for the entry and exit of air, exhaust, etc. may be provided to enable proper functioning of the engine(s).
- (d) A cockpit or cabin with transparent windshield giving direct forward visibility must be provided.

4.3.5.2 CLASS 1/2 A

- (a) Maximum engine capacity..... 1.5 cm³
- (b) Minimum projected wing area, including area covered by fuselage:..... 6 dm²
- (c) Maximum fuel capacity:..... 6 cm³
- (d) Minimum width of the fuselage at the cockpit:40 mm
- (e) Minimum depth of fuselage from the top of the cabin to the bottom of the fuselage, or in the case of an open cockpit model, from the top of the windshield to the bottom of the fuselage:.....75 mm
- (f) The engine cowling immediately adjacent to the engine shall not be included in the fuselage depth.
- (g) Minimum wheel diameter:25 mm
A tolerance of minus 3.0 mm will be permitted to allow for wear.
- (h) The distance between the centre of the control handle grip and the centre line of the model shall be 14.0 metres.
- (i) Minimum line diameter:0.25 mm (0.010 inch)
- (j) The load test shall be 20 times model weight.
- (k) The radius of the pilot's circle shall be 3 metres and the radius of the flight circle shall be 17.50 metres.
- (l) Race Distance:
 - (i) Heats and semi-finals shall be 100 laps (8.8 km).
 - (ii) Finals shall be 200 laps (17.6 km).
 - (iii) Maximum race time will be 8 minutes for the heats & 12 minutes for the final.

4.3.5.3 CLASS "B"

- (a) Engine capacity not less than 2.51 cm³ nor greater than 5.00 cm³
- (b) Minimum projected wing area, including the area covered by the fuselage:... 9 dm²
- (c) Maximum fuel capacity:..... 30 cm³

- (d) Minimum width of fuselage at cockpit:50 mm
- (e) Minimum depth of fuselage from the top of the cabin to the bottom of the fuselage, or in the case of an open cockpit model, from the top of the windshield to the bottom of the fuselage.....100 mm
- (f) The engine cowling immediately adjacent to the engine shall not be included in the fuselage depth.
- (g) Minimum wheel diameter25 mm
A tolerance of minus 3.0 mm will be permitted to allow for wear.
- (h) The distance between the centre of the control handle grip and the centre line of the model shall be 17.69 metres.
- (i) Minimum line diameters:
 - (i) 0.35 mm (0.014") for engine displacements of 2.51 to 3.5 cm³.
 - (ii) 0.4 mm (0.016") for engine displacements of 3.51 to 5.00 cm³.
- (j) The load test shall be 30 times model weight.
- (k) The radius of the pilot's circle shall be 3 metres and the radius of the flight circle shall be 21.2 metres.
- (l) Race Distance
 - (i) Heats and semi-finals shall be 90 laps (10 km).
 - (ii) Finals shall be 180 laps (20 km).
 - (iii) Maximum race time will be 8 minutes for the heats & 12 minutes for the final.
- (m) The maximum noise emitted from the model shall be restricted to 85 dB(A) at 7 metres, measured in accordance with the BMFA noise code.

4.3.5.4 CLASS BARTON B With acknowledgements to Barton MFC

4.3.5.4.1 General

Other than for safety reasons, the rules for Barton B Team Racing may only be altered with the approval of the Barton Model Flying Club.

4.3.5.4.2 Model Specification

- (a) Any class B or scaled up class A model design published before the end of December 1965. Scale models, or original designs along contemporary pre-1965 lines are also permitted. Flying wing or pod and boom designs shall not be permitted.
- (b) Models must have a clear cockpit and carry a dummy pilot.
- (c) Minimum projected wing area outside of the fuselage area.....8 dm² (125 in²)
- (d) Maximum fuel capacity..... 30cc
- (e) Minimum depth of the fuselage at the cockpit measured from the top of the dummy pilot's head to the bottom of the fuselage.....95.25 mm (3.75")
- (f) Minimum width of fuselage at the cockpit 50.8 mm (2")

- (g) Conventional two wheeled undercarriage to be used, with a minimum wheel diameter of 44.45 mm (1.75"). A tolerance of minus 3.0 mm will be permitted to allow for wear.
- (h) A fuel shut off must be fitted and it may be used during the race.
- (i) Pressure refuelling systems shall not be used.
- (j) Hot glove glow connections shall not be used.
- (k) The use of modern materials in high stress areas to improve safety and longevity is permissible but an all-moulded model is not.
- (l) Models must be brightly coloured and shall have BMFA numbers at least 25.4 mm (1") high on the outboard wing.
- (m) The builder of the model rule does not apply.

4.3.5.4.3 Engine specification

- (a) Engines shall be the Irvine 25 MK3 fitted with venturi part number X-IRV20-3240.
- (b) The venturi shall not be modified in any way.
- (c) No modifications to, or "blue printing" of, the engine is permitted.
- (d) Specialised bearings shall not be fitted to the engine.
- (e) Additional head shims part number X-IRV25-3065 may be fitted to adjust the compression ratio.
- (f) Glow plug type is not limited provided it fits the original seat.
- (g) A small amount may be machined off the exhaust stack to allow easier installation but the engine must still be capable of having the original silencer mounted by the original means. It is permissible to machine a small amount of metal from the top of the mounting lugs thus rendering them level to facilitate mounting in the model. An extended prop driver may be used.
- (h) Any infringement of the engine rules will mean a lifetime ban from flying this class.

4.3.5.4.4 Control system

- (a) The distance from the centre of the control handle to the centreline of the model shall be 17.07meters (56').
- (b) Two stranded steel cables of minimum bulk diameter 0.457mm (0.018") shall be used. Each of the cables shall have a minimum of seven strands of wire.
- (c) The control system shall be subject to a load test of 20 times the weight of the model.
- (d) A wrist strap attaching the pilot's wrist to the handle must be used during all flights.

4.3.5.4.5 Circle layout.

The radius of the pilots circle shall be 3 metres and the radius of the flight circle shall be 20.5 metres (67').

4.3.5.4.6 Propellers

- (a) Propellers shall be APC, Graupner or JFX Black Prop 8" x 8".
- (b) The minimum diameter of a propeller of the approved type shall be 7.5 inches to permit balancing and limited dressing of the propeller tips in the event of damage. Re-dressing of the tip of a damaged propeller which has been reduced to the

minimum diameter of 7.5 inches may still take place within 0.375 inches of those tips. Apart from the above and boring the hub to fit the prop shaft/spinner, no material may be removed from the propeller. No modification is allowed except to balance the propeller.

4.3.5.4.7 Fuel

- (a) Fuel shall be supplied by the organisers and will be Formula Irvine 10%.
- (b) All competitors will use the same fuel as supplied on race days.

4.3.5.4.8 Race Distance

- (a) Heats and semi-finals shall be 75 laps.
- (b) Finals shall be 150 laps.
- (c) Maximum race time will be 10 minutes for the heats & 15 minutes for the final.

4.3.6 PROFILE CLASS RULES

4.3.6.1 CLASSES OPEN GOODYEAR, BRITISH GOODYEAR AND MINI GOODYEAR

- (a) Models shall be models of Goodyear racing planes that have flown in Goodyear or Continental Trophy races or other NPRPA Formula 1 races.
- (b) Models shall be painted in a scale like fashion, ie in a colour scheme that might have been used on the full-size aircraft.
- (c) Model profiles shall be within 5% of scale linear dimensions, the scale being 1/8 except where noted below. (Note, to help in scaling up plans all full-size Formula 1 aircraft are required to have a minimum wing area of 66 ft².)
- (d) The tail area may be increased by 25% over the scale area to permit safe handling, either by increasing the mean chord and span equally or, provided that the appearance of the model is not drastically altered, by increasing the span alone.
- (d) Models shall have profile fuselages and engines shall be uncowed. Fuselage side cheeks shall be permitted but they must not cowl the engine.
- (f) The engine shall be side mounted with the cylinder head outboard. The thrust line of the engine shall be in line with, or outboard of, the outboard side of the fuselage.
- (g) Mono wheel undercarriages are permitted. The undercarriage need not be affixed to the model in the same place as on the full-size aircraft. The undercarriage leg(s) shall emerge from the fuselage profile at approximately the same position as the full-size aircraft.
- (h) The racing number of the full-size aircraft shall be displayed in similar positions on the model.
- (i) The BMFA number of one of the team members shall be displayed at a similar position to the licence number on the full-size aircraft.
- (j) The team, if so requested, shall provide a three view drawing to substantiate the scale outline of his model. The drawing shall be from a source acceptable to the Contest Director.

4.3.6.2 CLASS OPEN GOODYEAR.

4.3.6.2.1 Specifications

- (a) Minimum projected wing area, including the area covered by the fuselage 9.6 dm²
- (b) Maximum width of fuselage excluding cheeks:26 mm
- (c) Minimum wheel diameter:25 mm
A tolerance of minus 3.0 mm will be permitted to allow for wear.
- (d) Minimum line diameter:0.375 mm (0.015")
- (e) The load test shall be 20 times the model weight.
- (f) The distance between the centre of the control handle grip and the centre line of the model shall be 15.92 metres.
- (g) The radius of the pilots' circle shall be 3 metres and the radius of the flight circle shall be 19.6 metres.
- (h) A safety wire constructed from multi strand wire with a minimum bulk diameter of 0.47mm must be visibly and safely attached between the bellcrank pivot bolt and the engine(s)

4.3.6.2.2 Engines

- (a) Maximum engine capacities shall be:
 - (i) Any 2.5cm³
 - (ii) Any radially ported compression ignition engine of 3.5³ with an iron/steel piston liner assembly.
- (b) Integrally finned motors are not permitted
- (c) Exhaust extensions are not permitted.

4.3.6.2.3 Fuel System

- (a) Fuel feed from the tank to the engine must be by engine suction. Pressurised fuel feed systems are not permitted.
- (b) Refuelling must be carried out by use of hand held squeeze bottle. Pressure refuelling systems are not permitted.
- (c) Models must be refuelled at every pitstop.
- (d) Fuel for glow engines shall have a maximum content of 20% nitro-methane

4.3.6.2.4 Propellers

- (a) Any commercially available thermoplastic or glass-fibre filled thermoplastic propeller is allowed.
- (b) Manufacturers' maximum RPM limits must not be exceeded
- (c) Propellers specifically designed for electric flight (such as the Graupner black CAM-speed) are expressly forbidden.

4.3.6.2.5 Race Distance

- (a) Heats and semi-finals shall be 100 laps (10 km), with two mandatory pit stops.
- (b) Finals shall be 200 laps (20 km) , with five mandatory pit stops.

- (c) Maximum race time will be 10 minutes for the heats & 15 minutes for the final.

4.3.6.3 CLASS BRITISH GOODYEAR

4.3.6.3.1 General

The rules for Open Goodyear shall apply with the following differences.

4.3.6.3.2 Engines

- (a) Engines shall be any 2.5cm³ Oliver Tiger or PAW or clones thereof which have enjoyed a significant production run. All engines shall be compression ignition, have radial porting and an iron/steel piston liner assembly
- (b) Any replacement parts shall, wherever possible, be genuine items from the original manufacturer or elsewhere. Should such parts be unavailable, replacement parts shall be manufactured to the original specification and in the original material.
- (c) The only modification permitted is the removal of metal from any part.

4.3.6.3.3 Propellers

- (a) The propeller to be used on all engines is an APC 7"x6".
- (b) No modification is permitted except to balance the propeller. When balancing, material may only be removed from one blade.

4.3.6.3.4 The Model

When flown over grass, the model shall be fitted with a one or two wheel undercarriage carrying wheel(s) each with a minimum diameter of 48 mm. A tolerance of minus 3.0 mm will be permitted to allow for wear.

4.3.6.3.5 Fuel System

- (a) The fuel tank shall be mounted in such a way that the whole of the tank is outboard of the fuselage.

4.3.6.4 CLASS MINI GOODYEAR

The rules for Open Goodyear shall apply with the following differences.

4.3.6.4.1 Entry Restrictions

- (a) Junior Teams
At least one member of the team must be a junior. A competitor is considered to be a junior up to and including the calendar year in which he attains the age of 17.
- (b) Novice Teams
Both members of the team must be first time entries to any nationally advertised Mini Goodyear competition.
- (c) Senior Teams
All other Competitors

4.3.6.4.2 Model Specification

- (a) The model specifications shall be as for the Goodyear class with the following differences:
- (b) The model shall be a minimum of 1/12 scale copy of a Goodyear or similar full-size racing aeroplane.
- (c) All parts of the controls and control connections shall be external to the fabric of the model.
- (d) The model is not required to be fitted with an undercarriage.

4.3.6.4.3 Engine

- (a) Maximum capacity of 1.5 cm³ with compression ignition.
- (b) It may be any plain bearing engine which is or has been commercially available, or it may be any commercially available single ball race steel/iron engine.
- (c) It must not be modified in any way other than to alter the choke diameter and/or to replace the spray bar. The original induction system must be retained. If originally fitted with a spray bar, a spray bar must be retained.

4.3.6.4.4 Fuel

- (a) The fuel tank must be filled using a plastic squash bottle. Pressurised fuelling systems are not permitted.
- (b) Fuel feed from the fuel tank to the engine must be by engine suction. Pressurised fuel feed systems are not permitted.
- (c) Models are to be refuelled at each pit stop.
- (d) Engine cut-outs are permitted but are not mandatory.
- (e) The propeller must be a commercially available thermoplastic item (nylon or glass/nylon) and it must be unmodified except to reduce its diameter if required.

4.3.6.4.5 Lines

- (a) The distance between the centre of the control handle grip and the centre line of the model shall be 13.5 metres, plus or minus 50 mm.
- (b) Two stranded steel wires of minimum width 0.3mm (0.012") shall be used.
- (c) Each of the wires shall comprise a minimum of three strands.
- (d) The load test shall be 5Kg.
- (e) The radius of the single pilots' circle shall be 3 metres and the radius of the flight circle shall be 17 metres.

4.3.6.4.6 Contest Organisation

(The contest shall be run to BMFA Team Race rules with the following exceptions:

- (a) The circles shall be marked out on grass.
- (b) All models shall be hand launched.
- (c) There is no requirement to move to a defined pitting area but pitmen must move a safe distance from a model which is already in the process of being pitted.

- (d) With permission of the Contest Director, pitmen may enter the flight circle to retrieve a model which has landed, but he must then immediately move outside of the flight circle.
- (e) If a team has not completed its second pit stop in a heat or its fifth pit stop in a final by the end of the penultimate lap, timing of the team will continue until the last pit stop is completed plus one lap flown.
- (f) A complete lap must be flown between each pit stop. In the absence of such a lap the subsequent pit stop will not be counted.
- (g) The Contest Director at all times shall ensure that the conduct of the contest shall be such so as to encourage the participation of junior and novice competitors.

4.3.6.5 CLASS F2CN

F2C rules with BMFA variations shall apply with the following differences.

4.3.6.5.1 Engine & Fuel

- (a) Maximum engine capacity:..... 2.5 cm³
Engines with integral finned liners are not permitted.
- (b) Maximum fuel capacity:..... 15 cm³
- (c) Fuel feed from the fuel tank to the engine must be by engine suction. Pressurised fuel feed systems are not permitted.

4.3.6.5.2 Model

- (a) The models must have a profile fuselage with a shape representing a real aeroplane, including a canopy (which may be a drawn one), and must be at least 100 mm deep at the canopy.
- (b) The maximum width of the fuselage shall be no more than 26 mm.
- (c) The engine and tank shall not be enclosed.
- (d) The engine shall be side mounted such that the thrust line is level with, or outboard of, the outboard side of the fuselage with the cylinder head outboard.
- (e) Modified Goodyear models will be permitted but they must comply with the maximum fuel capacity. See paragraph 4.3.6.5.1.(b). Wing area and fuselage depth regulations shall not be enforced for these models.

4.3.6.5.3 Propellers

- (a) Any commercially available thermoplastic or glass fibre-filled thermoplastic propeller may be used.
- (b) Manufacturers' maximum RPM limits must not be exceeded.
- (c) Propellers specifically designed for electric flight (such as the Graupner black CAM-speed) are expressly forbidden.

4.3.6.5.4 Lines

- (a) The minimum line diameter for single strand wire shall be 0.3mm with a minus tolerance of 0.011mm.

- (b) If stranded line construction is used, these shall have a minimum of three strands and all strands shall be of equal diameter and the stranded combination shall have a minimum width of 0.34mm with no minus tolerance allowed.
- (c) The load test shall be 20 times the model weight.
- (d) The distance between the centre of the control handle grip and the centre line of the model shall be 15.92 metres.
- (e) The radius of the single pilots' circle shall be 3 metres and the radius of the flight circle shall be 19.6 metres.

4.3.6.5.5 Race Distance

- (a) Heats and semi-finals shall be 100 laps (10 km) with two mandatory pit stops.
- (b) Finals shall be 200 laps (20 km) with five mandatory pit stops.

4.3.7 Vintage Class Rules

4.3.7.1 Object

To assist organisers and participants in Vintage Team Racing events by providing a clearly defined code of practice which typically retains the original character of models and events prior to 1958.

4.3.7.2 Eligibility of Models

- (a) Models shall be either, scale or semi-scale in appearance and if semi- scale must have a raised windshield or cabin. The aspect ratio of the wing shall not be more than 8:1 or less than 4:1. The cockpit or cabin must contain a scale pilot the head of which shall be not less than 7/8 inches deep.
- (b) For **classes A and B**, must be built to a constructionally detailed and dimensioned plan or three-view published or kitted prior to 1st January 1958. January 1958 magazines are accepted as published in 1957. The model must comply with the accepted team racing rules at the time of publication. Exceptions to this rule may be permitted as follows:
 - (i) Where only photographic evidence of a plan was published before 1st January 1958 a plan drawn from a photograph, signed by the original designer and/or approved by the VTR committee.
- (c) For **class 1/2A**, models must be built to a constructionally detailed and dimensioned plan or three-view published or kitted prior to 1st January 1961. January 1961 magazines are accepted as published in 1960.

In addition the following types of model will be eligible for class 1/2A:

- (i) Any approved vintage class A model fitted with a 1.5cc engine and a 10cc fuel tank.
- (ii) Any approved vintage class B model which is scaled down to 1/2A specifications. The percentage reduction must be specified by the entrant for approval and scrutineering purposes.

4.3.7.3 Model Details

The following section gives typical (but not exhaustive) guidelines for what may or may not be allowed.

- (a) Structures may be strengthened for racing to current BMFA rules, using materials and methods consistent with the period. i.e. sheet and block replacing built-up structures and fabric. Where designs have wings of a built-up structure replaced with solid sheet, the wing thickness may be reduced.
- (b) Designs with split fuselage construction (e.g. Footprint) may be made in one piece. No metal pans, otherwise, type of engine installation and access can be to individual choice provided the original thrust line is maintained. Engine position, fore and aft, and cowling may be adjusted to suit different engine dimensions and weights.
- (c) The vertical position of the wing may be altered, e.g. designs with wings that are installed above the engine bearers, may now have the wing positioned below, low wings may be raised. There is no limitation to the amount of movement but in all other respects the profile and plan-view of the design must remain as plan, (except where otherwise stated, i.e. engine and cowling).
- (d) The elevators must be as per plan (no one-sided elevators).
- (e) Circular bellcranks are permitted, grouped lines are not. A minimum of 1" line spacing must be maintained, measured at the exit point at the wing tip. Lead-outs may be installed through, below or above the wing, according to choice. The connection between the lead-outs and lines must be external to the model. This applies to all Vintage Team Racing classes.
- (f) A working engine shut-off MUST be fitted. The shut-off must not be used in the air as race strategy. During the warm-up period the Contest Director may request engines to be stopped using the shut-off to demonstrate that it is a working shut-off. The penalty for use in the air as a race strategy is disqualification (DQ)
- (g) The use of Carbon, Kevlar or other resin bonded fibre is allowed for localised repairs only. Bonded nylon, silk or glass cloth can be used for skinning and flying surfaces may be pressed but no full mouldings are permitted.
- (h) There shall be no use of such modern features as multi-function valves and pressure refuelling.
- (i) The nose contours of models may be reconfigured to a profile of choice, i.e. to add or eliminate a spinner according to personal preference. Where a spinner is not fitted a domed safety nut, compliant with BMFA racing safety rules, must be fitted.
- (j) Glow plug activation systems shall be limited to commercial clips, two pin plugs or jack plugs. Any other system must be shown on the original plan of the model or have acceptable proof of use in the period.
- (k) The undercarriage wheel track shall be a minimum of 4inches. It shall comprise of two horizontally opposed main wheels, laterally placed and centred about the model's 'plan view' longitudinal centre. Ideally the u/c legs will be of equal length, the third component will be a tail skid/wheel.
- (l) Fuel tanks may be made from fibreglass or balsa as an alternative to metal.

4.3.7.4 Eligibility of Engines

- (a) A vintage engine is one where the design and MK number was advertised for sale prior to 1st January 1958, although the engine need not necessarily have been manufactured by that date.

- (b) The engine used in a model in the Vintage Team Racing classes shall either conform to the above or, if of a later design and manufacture, be a plain bearing, non-schnuerle ported engine, commercially advertised at some time.

Note: Schnuerle porting is defined as two or more directionally shaped ports, symmetrical about, and adjacent to, the exhaust port, normally in conjunction with, but not limited to, a flat topped piston.

- (c) The use of ETA 6C engines and Mk4 Oliver engines will be permitted as they are direct lineal descendants of earlier, scarce engines and offer no marked increase in performance.
- (d) Any engine modifications, replacement parts or hybrid engines must use materials and technology clearly in use for model aircraft engines used in team racing prior to 1st January 1958.

Class B glow engines must be loop scavenged with a baffle piston.

In the case of 1/2A and A classes, an engine's piston shape is not restricted. The tuner may then remove as much metal as he sees fit.

- (e) Bearings may be bushed with non-ferrous materials and liners may be chromed.
- (f) Peripheral jet carburettors are allowed.
- (g) A hybrid or replica engine must have an original crankcase or one using the same method of manufacture as the original crankcase (to qualify as original, it will be the manufacturer's original crankcase or a crankcase of an accepted replica). All other components may be a mix of different engines or custom made, in accordance with the technology of the time period.

4.3.7.5 Race Conduct

The conduct of the race shall be in accordance with the rules laid down for the conduct of Team Racing events in the current edition of the BMFA Contest Rules Book. In the interest of safety the Contest Director may, at his discretion, group model/teams according to their performance/competence.

Note: An exception to the above, in vintage racing, models already on the ground must avoid causing an obstruction to any landing models, either in the air or running in to their pit station. Unlike modern T/R there is no minimum over-fly height. Lines must be on the ground and a pitted model should not be released to undertake or foul a landing model. To do so is a DQ.

The pilot must be crouching with one hand on the ground at the start and during pit stops. (Ref: Team Racing General Rule 4.3.4.9 (d))

4.3.7.6 Proof of Authenticity

Scrutineering will be carried out at the discretion of the Contest Director and may include model/engine, tank capacity and lines. The onus of proof lies with the entrant for any model/engine/feature not listed and he must have acceptable provenance on the day of the contest.

4.3.7.7 The Circle

- (a) The radius of the pilot's circle shall be 9 feet 10 inches for all classes.
- (b) The flight circle shall be divided into six equal segments for the locations of the starting positions. The choice of starting segment shall be by means of a draw.

Note: The diameter of the flight circle appears in the class rules.

4.3.7.8 Lines

- (a) The control lines shall be measured from the centre of the handle to the centre of the model.
- (b) The control lines shall conform to current BMFA safety regulations for Team Racing. Each ready to-fly-system of handle/lines/model shall be subject to a pull test of 20 times the model weight.
- (c) Control lines will be attached immediately adjacent to and externally of the model, Connections at the handle end do not qualify in this context.

4.3.7.9 Vintage Team Racing Class 1/2A

4.3.7.9.1 Model Specification

Maximum engine capacity	1.5 cm ³
Minimum projected wing area	55 ins ²
Maximum fuel tank capacity including pipes	10 cm ³
Minimum fuselage width (at cockpit)	1.25 ins
Minimum fuselage depth (at cockpit).....	2.5 ins
Minimum wheel diameter.....	1.5 ins

4.3.7.9.2 Propeller

Only APC or Graupner propellers may be used. No reworking of propellers is allowed other than reducing the diameter and treating one blade for balance.

4.3.7.9.3 Lines

The line length from the centre line of the handle to the centre line of the model shall be 42 feet 0 inches.

The minimum line diameter shall be 0.012inches.

4.3.7.9.4 Race Distance

Heats will be run over 100 laps (5 miles)

Finals will be run over 200 laps (10 miles)

4.3.7.9.5 Flight Circle

The radius of the flight circle shall be 53 feet 6 inches.

4.3.7.9.6 Eligible Models

Model	Designer	Source	Date
6.5 (reduced Class B)		Accepted by VTRSIG	
½ Midget	W Musciano	Model Aviation	MA2/1950
Boeing P26A (scale)	P M H Lewis	Model Aircraft	MA123
Burley 1/2A		Accepted by VTRSIG	
Cream Puff		Accepted by VTRSIG	

Cupid		Accepted by VTRSIG	
Diddy Dice (reduced Class B)		C Taylor	
Estrellita Jr	F Ptaszkiewicz	Model Aviation	MA7/1950
Frog Hornet		Frog Kit	
Gnat Foursome		APS	
Half Pint		Aeromodeller Annual	
Hawker Tempest (scale)	CM Milford	Model Aviation	MA4/1955
Hyperion		Accepted by VTRSIG	
Keil Kraft Ranger		Keil Kraft Kit	
Little Warrior	M Bassett	Aeromodeller	
ME 109 (scale)	P M H Lewis	Model Aircraft	MA278
Mercury 1/2A Team Racer		Mercury Kit	
P40 Warhawk (scale)		Accepted by VTRSIG	
Panko Baby		Accepted by VTRSIG	
Skeeter	R Taccini	Model Aircraft	MA257
The Nurk	M Bassett		
The Weaver		Accepted by VTRSIG	
Shoestring (scale)	P Lewis	Model Aircraft	MA297
Veron Pinto		Veron Kit	
Wee Bipe	W Winter &	Model Aviation	MA7/194
W Schroder		Accepted by VTRSIG	
Wharfdale 1/2A	J Horton	Original Drawing	

4.3.7.9.7 Eligible Engines

AE 15	Albon Javelin/Sabre	AM 10/15
Byford Sabre 1.5	BWM 150	Byra 1.5
Cipolla 1.5	CS Tiger Cub	DC Sabre/Spitfire
ED Fury/Super Fury/Hawk/Cadet	Elfin 149 BB and BR	Frog 150/150R/Viper
JB Atom	Le Simone HR 15	Margaret Meteore
ME Snipe	MVVS 1.5	OK Cub Diesel
Oliver Tiger Cub (360) (non Schnuerle)		PAW 1.49
Russian MK17	Taifun Record/Hurrikan	Webra Record

4.3.7.10 Vintage Team Racing Class A

4.3.7.10.1 Model Specification

Maximum engine capacity	2.5 cm ³
Minimum projected wing area	70 ins ²
Maximum fuel tank capacity including pipes	15 cm ³
Minimum fuselage width (at cockpit)	1.5 ins
Minimum fuselage depth (at cockpit).....	3.0 ins
Minimum wheel diameter.....	1.5 ins

4.3.7.10.2 Deviation to the above specification

Class A models built to early FAI rules (eg Phfft) which therefore cannot comply with the above cockpit dimension definitions will be measured at an appropriate section.

4.3.7.10.3 Propellers

Propellers shall not be of the glass, carbon, Kevlar or other resin bonded types.

4.3.7.10.4 Lines

The line length from the centre line of the handle to the centre line of the model shall be 49 feet 5 inches. The minimum line diameter shall be 0.012 inches.

4.3.7.10.5 Race Distance

Heats will be run over 85 laps (5 miles)

Finals will be run over 170 laps (10 miles)

4.3.7.10.6 Flight Circle

The radius of the flight circle shall be 60 feet 11 inches.

4.3.7.10.7 Eligible Models

Model	Designer	Source	Date
Alien	W Woodrow	MA244	8/56
A-bus	J Johnson		
Arau	Portuguese	J Isidro	1957
Bambi	K Brenk		1957
Battler	R Moulton	Model Aviation	1950
Black Chiffon	C Milford	CL/486X	10/52
Burley	J Horton	J Horton	1954
Cannonball	J MacArthur		1955
Chingford Racer	L Haywood	Aeromodeller	1956
Competitor		Hearns Hobbies Australia	1951
Dimpled Dumpling	Mac Grimmett	D Finch	1956
Elfcat	T Millar		1952
Elliptical	J Horton	J Horton	1957
Fingerprint	Forresters Club		1956
Footprint	P Smith	CL/589X	6/55
Fury	R Mayers	Aeroflyte Kit (Australia)	1956
Gengangaren	M Hagberg	MA 264	11/57
Honeybug	F Ehling	Air Trials	
Hornet		Skyleada Kit	1951
Humpty Go-Kart	D Edmunds	Aeromodeller	1955
Hyperion	L Hayward	Aeromodeller	4/52
Jabberwocky	W Hume	CL/514X	6/53
Jambon	N Butcher	MA 99	4/51
Mac	S McGoun	Mercury Kit	1955
Mercury MkII		Mercury Kit	1951
Mew Gull	H A Thomas	CL/600	7/55
Midget Mustang	P Smith	Veron Kit	1950
Minibuster	P Smith	Veron Ki	

Nervansage	W Kroger	MA 200	1/55
Nike	D Edmunds	Aeromodeller	1954
Olympian	T Smith	South Bristol	1953
Pacemaker	S Rymill	CL/509X	4/53
PHHT IV	H Stouffs	AM 3-view	1957
Pluto	M Smith	MA 211	5/55
Ranger	W Dean	Keil Kraft Kit	1950
RO56	J Rohr		1957
Scout	W Dean	Keil Kraft Kit	1949
Shorty	B Deason	Australian Nats Winner	1957
Skyhawk	L Ellis	CL/687X	12/57
Starshell		Australian Kit Plan	
Sorcerer's Apprentice	N Butcher	CL/515X	6/53
Swift		Hearns Hobbies (Australia)	
Tarantula	J Horton	Wharfdale Club	1956
Texan	R Young	Mercury Kit	
Tiger Terror	J Muir	MA	1956
Time Traveller	D Edmunds	CL/642X	12/56
TK 4	R Moulton	CL/411X	1/51
Tomahawk	S Alexander		
Tornado	G Bergamaschi	Olimpic Kit (Italy)	1956
Voodoo Mk1	G Yeldham	G Yeldham	1953
Voodoo Mk5	P Stephens	Contest Kits	1957
William Henry	J Horton	J Horton	1955
Wolverine	Meadmore Bros	Australian Model Hobbies	12/51

4.3.7.10.8 Eligible Engines

Alag X3	AM 25	Barbini B40
Cox 15 (PB)	CS Oliver Mk3 Replica	CS Elfin 2.49 Replica
DC Rapier	Eifflaender Special	ED 246
Elfin 2.49	Enya 15D/15G (PB)	Frog 250/249BB
Fox 15 (PB)	Fuji 15 (PB)	Indian 'K' 2.5
K&B 15 (PB)	Oliver Tiger (Mks 2,3,4)	OS 15 (PB)
PAW 249 (PB Mks 2,3)	PAW Eifflaender Special Replica	PAW 2.49 VTR
R250 Rothwell	Russian Oliver Mk 3 Replica	Super Tigre G30
Silver Swallow	Webra 2.5 (Mach 1 & Winner)	

4.3.7.10.9 Special Provisions

In view of the probable dominance of Class A events by one type of Vintage engine, provision shall be made for an award to be given to the team using a Vintage engine, as defined in 4.3.7.10.8, other than the Oliver Tiger or one of its clones/replicas.

4.3.7.11 Vintage Team Racing Class B

4.3.7.11.1 Model Specification

Maximum engine Capacity	5.0 cm ³
Minimum engine capacity	2.51 cm ³
Maximum projected wing area.....	125 ins ²
Maximum fuel tank capacity including pipes	30 cm ³
Minimum fuselage width (at cockpit)	2.0 ins
Minimum fuselage depth (at cockpit).....	4.0 ins
Minimum wheel diameter.....	2.0 ins

4.3.7.11.2 Propellers

Propellers shall not be of the glass, carbon, Kevlar or other resin bonded types.

4.3.7.11.3 Lines

The line length from the centre line of the handle to the centre line of the model shall be 56 feet 0 inches.

The minimum line diameter shall be 0.0136 inches for single strand lines and 0.015 inches for multi-strand lines for models powered by engines with a capacity greater than 3.5 cm³.

For models powered by engines with a capacity of 3.5 cm³ or less, the diameter for single strand lines may be reduced to 0.012inches.

4.3.7.11.4 Race Distance

Heats will be run over 75 laps (5 miles)

Finals will be run over 150 laps (10 miles)

4.3.7.11.5 Flight Circle

The radius of the flight circle shall be 67 feet 6 inches.

4.3.7.11.6 Eligible Models

Model	Designer	Source	Date
Able Mabel	D Clark	MA News	1/50
Accelerator		Super Kits(Australia)	1/57
Auggie	D Shipton	D Shipton	1951
Bartlett Bullet	W Bartlett	Air Trails	?
Battler	R Moulton	Model Aviation	1950
Bluebottle	C S West	CL/526X	9/53
Blue Star	P Vittori	Modellismo	5/54
Cardinal Puff	C Taylor	MA 95	3/51
Challenger	L Schulman	MA News	?
Chatterbox	K Conrad	MA News	4/49
Chow Hound	B Thompson	Air Trails	3/52
Cirrus	R Bagot	Modele Reduit D'Avion	11/56
Delta	P Bataillou	A/M Annual	1954
Double Dice	C Taylor	C Taylor	955/6

Dude	T Carvalho	Flying Models	6/57
Estrella	T Millar	T Millar	5/50
Firecracker (Aus)		Australian Model Hobbies	8/50
Firecracker (USA)	D Ealy	MA News	12/51
Firecracker MkII (Aus)		Australian Model Hobbies	12/51
Gee-Mac	B Evans	MA 84	1951
Good News		Monarch Kit	12/54
Greenfly	C S West	MA 133	7/52
Hells Bells	G Rae	G Rae	1950
Hokey Pokey	T Millar	T Millar	
Hoofmark	M Ware	Model News (Australia)	9/57
Jack of Diamonds	K Muscutt	K Muscutt	1953
Jezebel		AM Annual	1953
Kestrel	P Godfrey	MA 238	5/56
Lap Master		Australia	
Lazy Daisy	P Wheeler	CL/428X	5/51
Leighnor Special	P Plecan	American Modeller	7/57
Man O'War	R Moulton	CL/383X	7/50
Mercury Mk 1	J Nunn	Mercury Kit	1950
Mew Gull	C Smith	Flying Models	1950
Midget Mustang	P Smith	Veron Kit	1949/50
Migrator	B Lutker	Aeromodeller	12/56
Nemesis		A/M Annual	1953
Nimbus	H Wilde	MA 230	2/56
Nucleus	W Woodrow	MA 223	2/57
Number 13		Accepted by VTRSIG	
Number 20	H Whitney	Aeromodeller	7/50
Ole Slippery	C Smith	Air Trails	1952
Pacer	W Dean	Keil Kraft Kit	1951
Philibuster	P Smith	Veron Kit	1950
Presto	H Hall	CL/481X	8/52
Quest	K Storey	Berkeley Kit	1951
Racer	D Shipton	D Shipton	1951
Racer	R Panko	D Shipton	1950
Rambler	G Moir	MA News	3/55
Rambler 55	G Moir	MA News	1/55
Red Lightning	D Rowe	MA 88	1951
Redskin	C Lee	Veco Kit	1953
Rivetier	G Rae	AM 1722	1950/1
Saint	K Marsh	K Marsh	1950
Scramble	J Jones	CL/454X	11/51
Scramble (Inverted engine)		C/L Technical Committee	
Scrambler		AM Annual	1955/6
Scout	W Dean	Keil Kraft Kit	1949
Sheik	K Johnson	MA News	1/54
Shorty		Australia	1956
Skidoo	C Smith	Air Trails	
Sloe Boat	A Greenwood	A Greenwood	1951
Sorcerer	P Cameron	CL/544X	3/54
Starbomb		Australian Model Hobbies	1952

Super Saint	K Marsh	CL/465X	2/52
Tantivy	C Taylor	CL/534X	1953
Teamster	H Stevenson	Flying Models	6/54
The Key	K Storey	Berkeley Kit	1949
The Key	K Storey	AM Annual	1950
Thunderbird	S McGoun	Mercury Kit	1955
Thunderbird Prototype	S McGoun	J Jones	1955
TK 4	R Moulton	CL/411X	1/51
Vantage	J Vanderbeek	Frog Kit	1953
White XI	D Walker	J Ridley	1956
White XIII	D Walker	J Ridley	1957
Wrangler	P Wright	MA News	7/53

4.3.7.11.7 Eligible Engines

Amco 3.5 PB/BB	AM35	DC 350/Manxman
Dooling 29	ED346	ETA19/29(all Mks)
Enya 19/29 (PB)	Fox19/25/29 (PB, X&R, '57)	Frog 500
Fuji 19/29 (PB)	K&B 19/29 (PB)	Merco 29
Miles Special	McCoy 19/29	OS 19/20/25/29/S30
PAW 19/29 (PB)	Super Tigre G12/29 '51ser	Veco 19/29 (PB)
Yulon 29/30		

Engines eligible for class A may also be used in class B providing they are of a minimum capacity of 2.51cc.

4.4.2 BMFA Variations on F2D

4.4.(1).5 Note that it is normal practice for fuel to be supplied by the organisers only at International and Open International events.

Centralised Competitions - The following is the minimum organisational requirement:

- Centre Circle Marshall, who shall be the Contest Director.
- Scorer / Timekeeper, one per competitor.
- Control Line Processor, to ensure correct line length and to perform the pull test before each flight (this is essential for safety reasons)

4.4.5 1/2A COMBAT

4.4.5.1 Object

The object of this class is to promote combat by encouraging flyers to enter a class which is cheaper to compete in than full FAI Combat.

4.4.5.2 Definition of a Combat Event

A combat event is a contest during which eliminating heats are followed by a final in which two competitors with their model aircraft fly in the same circle at the same moment for a predetermined time, the object being to cut a streamer attached on the longitudinal centre line of the opponent's model aircraft, points being awarded for each cut taken.

4.4.5.3 Definition of a Combat Model Aircraft

- (a) Model aircraft in which the propulsion energy is provided by a piston motor(s) and in which lift is obtained by aerodynamic forces acting on surfaces which remain fixed in flight, except for control surfaces.
- (b) The longitudinal centre line shall be defined as the axis of the propeller in case of a single engined model aircraft and the axis of symmetry in the case of multi-engine model aircraft.

4.4.5.4 The 1/2A Combat Site

A combat site must consist of two concentric circles which shall be marked on the ground.

- (a) The flight circle radius 17.5 metres.
- (b) The centre (piloting) circle: radius 2 metres.

The flight circle must be laid out on grass. The centre piloting circle may be laid out on grass or any other material having a maximum radius of 4 metres.

4.4.5.5 Competitor

The pilot, who shall be the entrant and known as the competitor, may employ a maximum of two mechanics in any one heat. (In exceptional circumstances of wet or extremely windy weather, an additional helper may be used as a streamer holder and must perform no other function for the duration of that combat period).

During active combat periods, the pilot and his mechanic(s) must wear protective headgear fitted with an effective retaining strap.

To avoid the catching of the opponent's lines the protruding parts of the helmet must be covered. No communication using electronic devices is allowed between the pilot and mechanics/persons outside the flying circle.

4.4.5.6 Characteristics of a 1/2A Combat Model

- (a) Any 1.5 cm³ capacity engine may be used and the use of a safety spinner nut is compulsory.
- (b) The engine must run on suction feed only, with the fuel tank mounted entirely outboard of the axis of the propeller.
- (c) Propellers MUST be commercially available thermoplastic items.
- (d) Fuel for compression ignition and glow engines is not restricted.
- (e) The model shall not carry any artificial aid to assist the cutting of the streamers.

4.4.5.7 Controls

- (a) The control line length must be 12.88 metres plus or minus 75 mm. It is measured from the inboard face of the grip of the control handle to the longitudinal centre line of the model.

- (b) The control line wire used shall be of multistrand construction with a minimum diameter of 0.34 mm. No free ends capable of entangling an opponents lines and no line splices shall be permitted. A safety strap connecting the competitor's wrist to the control handle must be provided by the competitor.
- (c) Before each heat any sets of lines which may be used must be checked for correct length. A pull test shall be applied to the assembled handle, control lines and model used in that heat. The pull test shall be equal to 10 kgf (22.5 lbs)
- (d) Line changes during the combat period shall be permitted.

4.4.5.8 Number of Models

Only one model will be allowed per bout.

4.4.5.9 Streamer

- (a) The streamer shall be crepe paper 2 metres long by 25 mm wide and shall be attached to the model by 2 metres of sisal string.
- (b) The streamer shall be attached to the model within the longitudinal centre line and a 3 inches maximum distance outboard on the model and must not become detached under normal flying conditions.

4.4.5.10 Method of Starting

- (a) All signals shall be both acoustic and visual.
- (b) During the starting period the launching positions must be separated by at least a quarter of a lap. The first named competitor in the draw shall have the choice of streamer colour and the other the choice of starting position
- (c) The motor(s) must be started by flicking the propeller by hand.
- (d) A first signal, given by the Circle Marshal, shall signify the beginning of the 60 seconds period when the mechanic(s) or the pilot have the opportunity to start, run and adjust their motors.
- (e) A second signal, given by the Official Timer, shall signify the beginning of the combat period on or after which the model aircraft may be launched.
- (f) From the moment the Official Timer has given the signal to launch the combat heat lasts for four minutes.
- (g) When the Circle Marshal is satisfied that each model aircraft has completed two level laps, anticlockwise, separated by approximately half a lap, he will give a signal that combat may commence.
- (h) Combat may begin after a restart signal from the Circle Marshal following an interruption when one or both model aircraft have been grounded. This signal shall be given as soon as the Circle Marshal is satisfied that there is approximately half a lap separation between the two model aircraft.

4.4.5.11 Termination of the Contest

- (a) The Circle Marshal shall give an acoustic signal to terminate the combat heat four minutes after the signal to launch, i.e. five minutes after the first signal to run and adjust motors.
- (b) The same acoustic signal shall be given if the heat has to be terminated due to disqualification of one or both competitors or for any other reason.

- (c) The Circle Marshal shall signal both pilots to fly level and anti-clockwise and to cease combat when both streamer strings have been cut. If one pilot has only the string remaining he may request the circle marshal instruct both pilots to fly level and anti-clockwise and to cease combat. This decision may not be reversed, once made.

4.4.5.12 Method of Scoring

- (a) Scoring shall commence from the signal to launch and continue for the four minute period.
- (b) 100 points shall be awarded for each distinct cut off the opponent's streamer.
There is a cut each time the model aircraft, propeller or lines fly through the opponent's streamer resulting in particle(s) becoming detached from the streamer.
- (c) A cut must contain at least one part of the streamer. A cut that contains string alone will not count.
- (d) Should the string become detached from the model aircraft while airborne the competitor shall be penalised by 100 points and must immediately on a signal from the Circle Marshal land and replace the streamer. Ground time will be counted from the moment of such a signal being given. If after a mid-air collision no streamer can be found and the streamer retaining device is missing or bent, then, with the permission of the judges, it is acceptable to continue the heat without replacing the streamer.
- (e) One point shall be awarded for each whole second that a model aircraft is airborne during the four minute period.
- (f) Each whole second of stay on the ground of the model aircraft shall be penalised by 1 point. In the case of a model aircraft fly-away, with or without lines, this ground time shall commence from the moment of such fly-away.
- (g) Each warnable offence shall be penalised by the deduction of 40 points from the competitor's score.
- (h) Should the mechanic(s) damage the streamer, or the model aircraft cut its own streamer, whilst the model aircraft is on the ground the mechanic(s) must replace it with a new streamer. If they launch the model aircraft without so replacing it, the competitor shall be penalised by 100 points. Ground time will be counted while the model aircraft is airborne with the damaged streamer.
- (i) In the case of a line tangle where the circle marshal estimates the tangle cannot be cleared, he can require both pilots to land immediately. Ground time for both pilots will start from the circle marshal's signal. After the models have landed the heat will continue as normal.

4.4.5.13 Attempts

Only one attempt will normally be allowed to complete a combat heat except for when:

- (a) A streamer breaks
- (b) In the event of a model aircraft fly-away, as a result of the lines having been severed by his opponent's model aircraft, lines or engine, in which the model aircraft and streamer may not be retrievable due to the distance flown, the circle marshal asks the affected pilot whether he wants a new attempt or not. The affected pilot must respond immediately, without consulting others about the status of the heat. If the pilot wants to continue the flight he must use a new full-length streamer.

The pilots should be informed before the beginning of the competition where the fly-away area is defined. This area should be clearly defined by the organisers.

- (c) In the event of a line tangle resulting in the control line(s) breaking and only one model aircraft being grounded, making it impossible to clear the line tangle.
- (d) If, as a result of a line tangle, an opponent's model aircraft cuts its own streamer in flight or the streamer, unless only string remains, becomes wrapped around the model aircraft and/or the lines, the heat shall be re-flown.

4.4.5.14 Conduct

- (a) A pilot must remain inside the centre circle while his model is flying except at the moment of release of his model by the pitman.
- (b) After a mid-air collision the heat shall continue as if both models had landed.

4.4.5.15 Offences

The following are warnable offences and each and every occurrence will attract the appropriate penalties (subject to 4.4.5.12.(g))

- (a) If a pilot unintentionally leaves the centre circle while his model is airborne.
- (b) During the bout the mechanics enter the flying circle at an oblique angle or cut across the flying circle to reach a downed model. One penalty only will be incurred for each offence even if more than one mechanic is involved.
- (c) If the mechanic(s)/pilot do not immediately, or after a line disentanglement, withdraw a grounded model to outside the 17.5 metre circle prior to servicing it.
- (d) If the model is launched prior to the starting signal.

4.4.5.16 Cancellation of the Flight (Disqualification)

An entrant will be eliminated from the heat and his opponent declared the winner if:

- (a) He deliberately attacks the streamer of his opponent's model prior to the Circle Marshall's signal to commence.
- (b) His model fails to become airborne within two minutes of the signal to launch.
- (c) He attempts to fly a model which at the time of launch does not have a strong effective control mechanism, or does not have a secure engine attachment, or does not have a running engine.
- (d) He interferes with his opponent, or forces his opponent to leave the centre circle.
- (e) He deliberately flies in a dangerous manner.
- (f) He attacks his opponents streamer without his own, or the remaining parts, attached to his model.
- (g) He is not present at his allotted flight time, unless he has the express permission of the Circle Marshal.
- (h) He leaves the centre circle, intentionally whilst his model is flying, or without informing his opponent of his intention to do so when his model is grounded for a purpose other than to allow his model to be serviced.
- (i) He deliberately leaves the centre circle, for a purpose other than to allow his model to be serviced, without wearing protective headgear.
- (j) He flies in such a manner as to inhibit his opponent, or his opponent's pit crew, from clearing any line entanglement.

- (k) He flies other than level in an anti-clockwise direction when only his model is in the air and there is no line entanglement.
- (l) Attacking the opponents streamer before the start signal is given by the Circle Marshal (see 4.4.5.10).
- (m) For any other flagrant breach of the rules
- (n) He releases the handle, or removes the safety strap, for any reason, while the model is flying.
- (o) He deliberately attacks or interferes with his opponents continuously level flying model, which clearly has no paper streamer left.
- (p) He fails to clear any line tangle prior to relaunching his model.

4.4.5.17 Classification

- (a) The contest shall be run as a knock-tournament.
- (b) The contestant who obtains the highest score in points shall be the winner of each bout.
- (c) A competitor shall be eliminated from the competition when he has lost two bouts.
- (d) Each round shall be randomly drawn from the competitors remaining in the competition
- (e) In the event of an unattached competitor remaining in any round, that competitor shall be matched with the first competitor drawn in the next round and (if he/she is not eliminated) in each successive round, unless such time as there is again an unmatched competitor remaining in a round. At that time these two competitors shall be matched to complete that round.
- (f) In the event of a tie for second and third place (both cannot happen) fly them off using the above procedures except allowing only one loss during the fly-off.
- (g) In the event of a two way tie for third remaining after a fly-off for second, match them with the winner to take third.
- (h) In the event of a tie score in any bout, that bout shall be re flown. A bout is considered a tie if the score difference is 5 points or less.

4.4.5.18 Contest Procedure

Under normal circumstances the contest will be run as 4.4.5.17 (a) to (h) except where the number of entries does not permit this. Should this situation arise the following system will be used:

- (a) Contestants will normally compete with each other in a knockout competition chosen by random draw. The losers of each of the first round flights will be allowed to compete in a further losers re-fly round.
- (b) The winners from this round will be drawn with winners from the first round to provide a second round of contests.
- (c) The rounds will continue until eight contestants are left so that quarter, semi and final round provide an overall winner.

4.4.5.19 Judges and Timekeepers

The following is the minimum organisational requirement:

- (a) A Centre Circle Marshal, who shall be the Contest Director.

- (b) Two Scorer / Timekeepers (one per competitor).
- (c) One Control Line Processor, to ensure correct line length and to perform the pull test before each flight (this is essential for safety reasons).

4.4.6 1/2A DIESEL COMBAT

4.4.6.1 Object

To provide an event based on 1/2A Combat but with easily and cheaply available plain bearing 1.5 cm³ diesel engines.

4.4.6.2 Engine

The engine will be a PAW 1.5 cc plain bearing diesel and the use of a safety spinner nut is compulsory.

4.4.6.3 Fuel

Fuel is not restricted.

4.4.6.4 Lines

The control line length from the inboard face of the grip of the control handle to the longitudinal centre line of the model shall be 42 ft 3 in (12.875 metres) plus or minus 1.5 in (0.04 metre).

4.4.6.5 Scoring

Scoring will be as per Vintage Combat four minute bout rules (4 points per cut, less one point per 15 seconds ground time).

4.4.6.6 General

All other rules shall be as Class 4.4.5 1/2A combat.

4.4.7 VINTAGE COMBAT

4.4.7.1 The Model

- (a) This is a limited performance class and performance levels are restricted by strict control of model design, engine design and engine modification.
- (b) A vintage combat model must be built in accordance with a design which was in common use prior to and up to 31st December, 1974 or was kitted prior to that date. Only models which are on the approved list may be used.
- (c) Models **MUST** be an accurate plan view of the original. The following alterations are permitted:
 - (1) Addition to or omission of sheeted areas, i.e. centre sheeting.
 - (2) Changes to wing section or internal structure or degree of asymmetry of wing (i.e. whilst retaining the original wing outline, the engine pod and

elevator may be moved inboard or outboard to give a different degree of asymmetry to the wing.)

- (3) Additional booms or replacement of wire booms with wooden ones and vice versa and spacing of booms (noting that the original elevator size and hinge moment must be maintained..
 - (4) Recessing the engine into the leading edge.
 - (5) A balanced elevator may be changed to a conventional elevator and vice-versa. The elevator must retain the original outline.
 - (6) Such changes must be carried out using constructional techniques that were commonly used at the time that the model was in use. The use of carbon, kevlar or boron fibre reinforcement is not permitted. Modern adhesives are permitted. Neither Styrofoam nor any expanded foam may be used.
 - (7) Models must not exceed original overall dimensions or be more than 6 mm smaller on any dimension. Elevators must be dimensionally accurate.
 - (8) Fins and fences may be omitted or altered.
 - (9) Where the original model had an upright engine this may be converted to 'sidewinder'.
 - (10) Any model that exceeds 36" wing span or 11.5" elevator hinge moment (leading edge to elevator hinge line) will not be allowed to compete.
 - (11) The curvature of the wing tips (defined as the last 50 mm of each wing) may be changed but such changes must not add any area to the wing.
 - (12) It is permissible to strengthen the engine pod in excess of plan
 - (13) External gussets may be used around tail booms, the dimension of the hypotenuse of such gussets may not exceed 20 mm.
 - (14) Metal bearers are not allowed.
- (d) The following alterations are NOT permitted
- (1) Any change to the original plan view except those outlined in b.3 , b.4, b.5, b.7, b.8 and b.9 above. In particular, no smaller or larger elevators, no increase in wing span, root chord or tip chord, filling in between booms unless specifically permitted, as in the case of Yeti 1. Where any dispute arises, the designers opinion will be given priority.

Note

The CD may decide not to accept a model which, in their opinion, has been altered in outline so as to change the appearance or performance of the model as originally designed. Examples of such changes would be, for instance, elevator shapes and sizes being altered and external bellcranks which should be internal.

The onus of proof in any such case must always lie with the competitor.

By allowing a model to compete in the first round the Contest Director (CD) signals his acceptance that the model is 'legal' and it will be considered to be processed. That model may not subsequently be disqualified unless 'illegal' parts are added. Combat damage that occurs during a competition will not be grounds for disqualification unless safety is compromised. The CD will point out any illegalities observed prior to a bout and will give the competitor(s) the opportunity to make the infringement good.

- (e) The model shall be covered in a material that was available at the time that the model was in use, i.e. tissue, glass cloth, nylon fabric, silk fabric, terylene netting or a combination of them. In addition, heat shrink fabric coverings, such as Solartex, Glosstex or Polytex, may be used but heat shrink plastic film coverings, such as Solarfilm, Monocote or Micafilm, are not permitted.

The use of ICAREX/VENTEX type kite material or AIRSPAN/LITESPAN synthetic tissue over MYLAR is permitted.

Models shall not be all white. As a minimum at least the elevator must be coloured.

- (f) The name (and mark no.) plus the year of the model must be clearly visible on the upper flying surfaces.
- (g) No design will be added to this list until it has been considered by the Fliers meeting. No modifications to plan will be permitted other than at the above meeting.

(h) The approved list of Vintage Combat models is as follows:

MODEL	DESIGNER	SOURCE	DATE
Anduril 1 & 2	Mick Tiernan (UK)	Frank Smart	1970
Anduril '74	Mick Tiernan (UK)	Mick Tiernan	1974
Apache		A.M. Annual	1970/71 p72
Assagai	Alan Thompson	Frank Smart	1968
Assagai XL	Alan Thompson	Frank Smart	1968
Banshee	Mike Davis (UK)	Frank Smart	1968
Barbarian	John Dixon (UK)	Frank Smart	1969
Barbarian XL	John Dixon (UK)	Frank Smart	1969
Billy Bones	Dave Packwood (UK)	Frank Smart	1963
Boogy-man	Terry Lee (UK)	A.M.	Jun 1964
Bumblebug	Vernon Hunt (UK)	Frank Smart	1969
Buzzard	Neil Blackburn (UK)	Frank Smart	1970
Chaos	Peter Freebrey (UK)	A.M	Jun 1963 p294
Chip Chop	Jose Vicente Segrelles	Jose Vicente Segrelles	El Aeromodelo (Spain) March 1973
Cleaver	George Copeman (UK)	A.M.799	Sep 1961 p466
Cobra II	Don Halls (Australia)	A.M.	May 1968
Combat King		Contest Kits	
Delta	Martin Kizsel	Martin Kizsel	1974
Device	Steve Malone	Steve Malone	1973
Diamond	Alec Herring	Alec Herring	1972
Dominator	Mike Davis (UK)	A.M.893	Dec 1965 p581
Dongus	Johnson/Pinckert (USA)	A.M.789	Feb 61 p74-75
Duellist	A Tristany (Spain)	A.M.648	Mar 1957 p150
Early Bird	Richard Wilkins(UK)	M.A.1022	Sep 1965 p232
Falco		A.M. Annual	1963/64 p106
Flingel Bunt	Stu Holland (UK)	A.M	Jan 1965 p20
Freecloud	Bob Morgan	Frank Smart	1970
Gladiator	G.F. (UK)	Frog Kit	
Gunslinger Mks 1,2 & 3	E Varley & Fred Pateman	Frank Smart	1963
Hornet 3	Frank Smart	A.M.	April 1974 1974
Hornet XL	Frank Smart	Frank Smart	1974

Ironmonger	Richard Evans (UK)	A.M. Oct 71 p550	1970
Jaguar Mk 1	Mick Chesterton (UK)	Frank Smart	1969
Junior Satan	Carl Goldberg (USA)	Goldberg Kit (A.M.)	Nov 1964
(new)Junior Monitor(II)	Henry J Nichols (UK)	Mercury Kit	
Jupiter	Phil Jackson	Stuart Vickers	1962
Kanible	John Dixon (UK)	A.M. Annual 1	968/69 p92
Kanible GT	John Dixon (UK)	Frank Smart	1968
Kanible GTO	John Dixon	Frank Smart	1969
Karnivore	Dave Gibbard	Frank Smart	1961
King Twister	Mick Chesterton (UK)	Frank Smart	1967
Kombat Kapers	R Gibbard (UK)	A.M.	Jan 1954
Komm-Batt		A.M. 288	Aug 1958 p278
Liquidator	Frank Dowling (UK)	A.M. 998	May 1969 p230
Liquidator XL	Frank Dowling (UK)	A.M. 998	May 1969 p230
Mini - Voodoo	Riley Wooton (USA)	A.M.	May 1963
Mister Pogle	Terry Mortimer (UK)	Frank Smart	1965-1967
Nemesis	Howard Rush	Frank Smart	1970 (USA)
Oliver Twist Mk 6	Martyn Cowley (UK)	Frank Smart	1969
Oliver Twist Mk 7	Martyn Cowley (UK)	Frank Smart	1970
Olympic Rocket	C. Bergamaschi (Italy)	Kit	(A.M.) Apr 62
Pallisandra		A.M. Annual	1960/61 p77
Pallisandra		C.L. Manual	1961 p131
Panic	Peter Freebrey (UK)	American Modeller	Jan-Feb 1965
Piraja		A.M. Annual	1965/66 p46
Piranha Mk 1	Frank Smart (UK)	Frank Smart	1968
Piranha Mk 2	Frank Smart (UK)	Frank Smart	1969
Piranha XL	Frank Smart (UK)	Frank Smart	1969
Proton	O.F.W. Fisher (UK)	Performance Kits	Apr 1959
Pygar	Mick Lewis	Mick Lewis	1974
Razor Blade	Pete Tribe (UK)	A.M. 729	Mar 1959 p222
Razor Blade `64	Pete Tribe (UK)	A.M. 729	Jul 1964 p332
Rhino Mk 5	John Dixon (UK)	Frank Smart	Apr 1967
Riot-Act 1 & 2	Andrew Longhurst	Frank Smart	968
Rogue	A.M. Staff (UK)	A.M. 716	Dec 1958 p643
Satana		A.M. Annual	1969/70 p32
Schuco-Hegi 160	(Germany)	A.M. Annual	1959/60 p83
Scorcher	(UK)	Frog Kit	1969
Sennapod		M.A. 389	Mar 1964 p90
September Warrior	Bazz Bumstead (UK)	M.A. 385	Nov 1963 p334
Shim-Shek 1 & 2	Turner (UK)	Frank Smart	1963
Shogun	Dave Wiseman	Dave Wiseman	1973
Shrike	(UK)	A.M. 634	Sep 1956 p484
Shuffler MK 2	Frank Smart		
Splinter	Bill Netzeband (USA)	American Modeller	Apr 1967 p30
Squig	J Benoy (UK)	A.M.	Jul 1961
Streamer Eater	A. Ytreoy (Norway)	A.M. 883	Jun 1965 p280
Stockport Warlord	Graham Howard	Frank Smart	1968
Styrobat	Peter Short (UK)	A.M.	Jan 1967
Supermonger	Richard Evans	Richard Evans	1974
Super Twister	John Chamberlain (UK)	John Chamberlain	1967

Super Twister XL	John Chamberlain (UK)	John Chamberlain	1967
Sword	J Templeman (UK)	A.M.674	Oct1957p518
Talon	Dave Platt (UK)	Keil Kraft Kit	
Taper- Wing	Arthur Garnett (UK)	Frank Smart	
Terminator	Stu Holland (Eire)		1970
Terminator	Mick Davies	Frank Smart	1970
The Proposition		A.M.Annual	1955/56 p88
Titan Mk 1	John Shaw (UK)	Frank Smart	1966
Titan Mk 4	John Shaw (UK)	Frank Smart	
Titan Mk 5	John Shaw (UK)	Frank Smart	1969
Toreador	Henry J Nichols (UK)	Mercury Kit	
Turncoat	Moggs Morris (UK)	A.M.926	Feb 1967 p74
Twister Mk 1	John Chamberlain (UK)	Frank Smart	1965
Twister Mk 4	John Chamberlain (UK)	Frank Smart	1966
Twister Mk 9	John Chamberlain (UK)	Frank Smart	1969
Twister Mk 10	John Chamberlain (UK)	Frank Smart	1970
U.F.O.	Dave Budd (UK)	Frank Smart	1968
Unlimited	R. Smith (UK)	A.M.369	Dec 1980 p656
Warlock	Richard Evans	Frank Smart	1967
Warlock	Steve French	Frank Smart	1969/70
Warlord	Mick Chilton (UK)	Frank Smart	1968 - 1972
Warlord	Heanor MAC (UK)	A.M.Annual	1968/69 p77
Warlord	Vernon Hunt (UK)	Pegasus Kit	(AM) Jul 1972
Warlord	John Dunker	Frank Smart	1968
Warlord XL	Vernon Hunt	Vernon Hunt	1972
Warmonger Mk 1	John Dixon (UK)	Frank Smart	1965
Warmonger Mk 2	John Dixon (UK)	Model Avia (France)	Feb 1968
Warmonger Mk 2XL	John Dixon (UK)	John Dixon	1968
Warmonger Mk 3	John Dixon (UK)	Frank Smart	1969
Warrior	Frank Smart (UK)	Frank Smart	1970
Wildcat	(USA)	Bradshaw M.P. Kit	(AM) Mar 1963
The Yeti 1 & 2	John Dixon (UK)	Frank Smart	1965
Zack-Zack	Klaus Seegers (Germany)	C.L.Manual	1961 p131
Zig-Zag	Brian Mills (UK)		1965
Zot-Box 'N'	Cpl Red Phin (Australia)	Frank Smart	1966
Zot-Box 'M'	Cpl Red Phin (Australia)	Frank Smart	1967-1968

The following models, due to their undoubted status as 'Classics' will be allowed to compete despite the fact that they may exceed the dimensional limits :-

Mr Pogle	Terry Mortimer (UK)	Frank Smart	1965
Orcrist	Steve Jones (UK)	AM Oct 71 p550	1969
Razor Blade 1964	Peter Tribe (UK)	AM 729	July 1964 p 332
Ruteress	Steffan Larson (Swe)	AM 969	Dec 1968 p657

IMPORTANT NOTE

Simon Miller is running the mail order Vintage Combat Model Plans service. This scheme is highly recommended and for more information and price lists, please send an A5 SAE to: Simon Miller at 19 Mill Rd., TILLINGHAM, Essex, CM0 7SY or email Simon at admin@combatflyers.co.uk or call on 07762301246

It is strongly recommended that potential competitors ascertain eligibility of a design for the intended class before commencing building, by contacting Simon Miller.

With all 'approved' models on the list, the dimensional requirements of 4.4.7.1.(10) take precedence. Competitors should note that there may still be models on the list that are now ineligible and should check accordingly.

4.4.7.2 Engine

- (a) The engine shall be a diesel of 3.2 cm³ maximum displacement if constructed with ball/roller races or 3.5 cm³ maximum displacement if constructed with plain bearing crankshaft. Engines permitted under this definition (any mark or model unless otherwise stated) are as follows:

AM 25CS	Oliver Mk 3 Replica	DC Rapier
AM 35	ED Racer	Enya 15D
Elfin 249	ETA 15	Frog 249
OS 15D	Oliver Tiger Mks. 2,3 ,4	PAW 249, 249 TBR CT 1 & 2
Rivers Silver Streak	PAW 19D and 19 D	CTMVVS 2.5/1958 TRS & D7
Super Tigre G30	Russian Oliver Mk 3	Replica Super Tigre G20/15D
Taifun Orkan	Rothwell 250	Webra Mach 1 and 2
PARRA T3 (2.5cc)	T4 (3.2cc)	

The Rothwell 320 TBR, PAW 19 TBR, PAW 19 BR and the Oliver Tiger Mk4 19 TBR are allowed subject to not being increased in capacity.

The retro fitting of a single ball race in PAW 19 sized plain bearing motors is allowed.

MVVS 15D 2.5cc (Current model, and subject to the following restrictions)

- (1) Standard engines only to be used, no tuning allowed.
 - (2) Standard sized venturi, 3.5mm.
 - (3) Bearings may be replaced by steel bearings of the same size.
 - (4) No bushings to bearings, phenolic or ceramic bearings permitted.
 - (5) The only modifications permitted to the engine is the removal of the exhaust stub, and the positioning of the exhaust port to either side or rear exit.
 - (6) Prop size is up to the operator, but only nylon props to be used.
 - (7) These rules apply only to the front induction MVVS 15.
 - (8) The rear induction disc valve engine will not be permitted, nor will the use of the MVVS ABC LINERED ENGINE, CONVERTED FROM GLOW.
- (b) The engine must be fitted with a domed safety spinner nut.
- (c) Only suction fuel feed systems are permitted.
- (d) The propeller, for engines above 2.5 cm³, must be a commercially available 8" x 6" thermoplastic item whilst 2.5 cm³ engines may use any commercially available thermoplastic propeller. The propeller may not be re-worked except that one blade may be modified for balancing purposes and the hole in the hub may be enlarged.
- (e) The engine must contain the manufacturers original crankcase, liner and crankshaft, in the original materials. These components may be modified by removal of metal and/or chroming. Such modifications may not reduce the weight of the motor (minus spinner and spraybar) by more than 5 grams. Ceramic products may not be used.

- (f) All Vintage Combat models are subject to a speed limit of 26 seconds for 10 laps. This to be measured without the streamer and with the handle on the pilot's chest. Any flier found to be exceeding the speed limit must demonstrate to the Contest Director that he is within the speed limit before being allowed to re-fly the bout otherwise he will be eliminated from the competition.

4.4.7.3 Lines

- (a) Control line length must be 15.92 metres plus or minus 75 mm. It is measured from the inboard face of the grip of the control handle to the longitudinal centre line of the model.
- (b) The longitudinal centre line shall be defined as the axis of the propeller.
- (c) Only two line control is permitted and each of these lines shall be multi-strand and of a minimum diameter of 0.34 mm. No free ends capable of entangling an opponents lines and no line splices shall be permitted. Line connectors at the handle end should be sleeved. A safety strap connecting the competitor's wrist to the control handle must be provided by the competitor. This strap will be subject to the full pull test separately to the line pull test and must be worn at all times while his model is flying. See drawing.

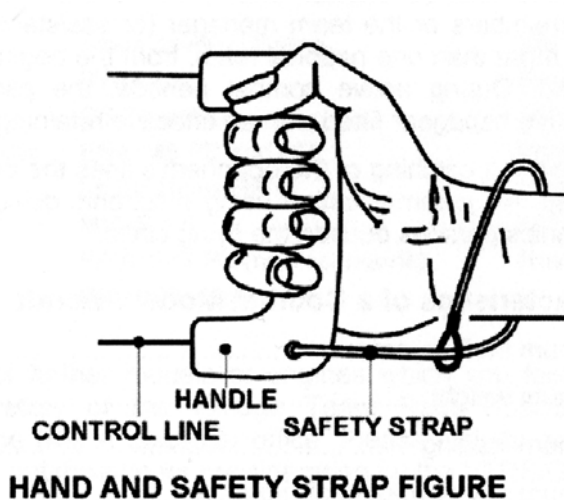

- (d) Line changes during the combat period shall be permitted.
- (e) A line pull test shall be applied to the assembled handle, control lines and model. Replacement lines must be pull tested by the Circle Marshal before the model is relaunched. Failure to do so will result in disqualification. The pull test will be equal to 100 Newtons (10kgf).

4.4.7.4 Combat Site

A combat site must consist of two concentric circles which shall be marked on the ground.

- (a) The flight circle: radius 20 metres
- (b) The centre (piloting) circle: radius 2 metres.

The flight circle must be laid out on grass. The centre piloting circle may be laid out on grass or any other material having a maximum radius of 4 metres.

4.4.7.5 Streamers

The streamer shall consist of double weight crepe paper (80 g/m²) or any replacement of equivalent strength, not less than 2,25 m or more than 3 m long and 3 +/- 0,5 cm wide, fixed to a sisal string of 2,5 m minimum length. All streamers must be of the same length. There shall be a clearly visible ink mark 2,5 m from the junction of the string and streamer. The streamer shall be attached to the model aircraft in such a way that the ink mark is level with, or behind, the rearmost portion of the model aircraft (see sketch). The attachment part of the string shall have a minimum length of 0,75 metre. The attachment end of the streamer shall be reinforced on either side by tape approximately 2 cm wide affixed diagonally to the length of the streamer with one at right angles to the other and extending for a maximum of 5 cm. An additional fibre/fabric reinforced tape 2 cm wide is affixed across the streamer (see detail below).

The streamer must be attached through the longitudinal centre line of the model.

The colour of the streamer must be different for the two competitors in the heat. Each pilot/pit crew shall be issued with a streamer at the start of the heat by the centre marshal. A second streamer will be available from the centre marshal when needed.

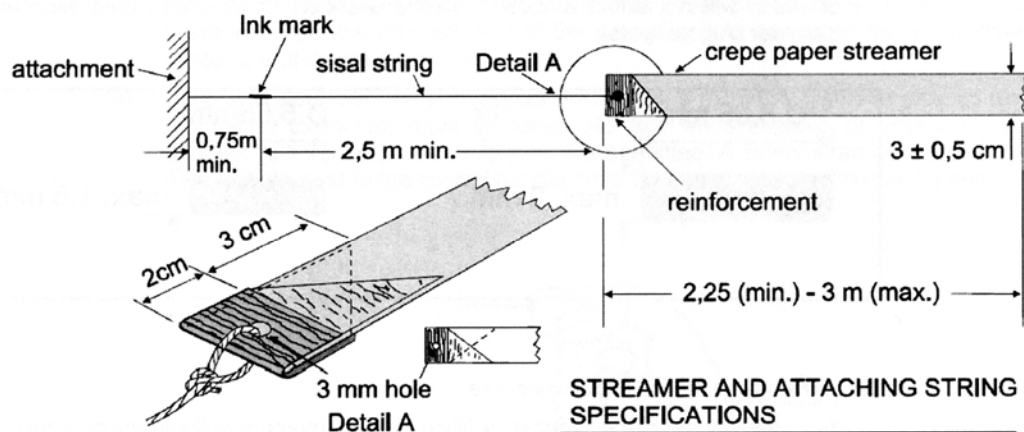

4.4.7.6 Number of Models

A contestant will be allowed to use one model per bout.

4.4.7.7 Pitcrew

Two pitcrew are allowed per contestant. During the combat period the pilot and the mechanic(s) must wear protective headgear fitted with an effective retaining strap. In exceptional circumstances of wet or windy weather an additional helper may be used as a streamer holder and must perform no other task during the bout. The helper must wear protective headgear. Whilst it is permissible for pilots to wear the baseball style 'Bump' caps, pitmen should wear more substantial protective headgear

4.4.7.8 Officials

- A contest shall normally be run by a Circle Marshal, who shall be the overall timekeeper, and one scorer per contestant.
- The Centre Marshal must wear protective headgear.
- The scorers should hold their stopwatches so that observers can read them.

- (d) The total time of each pit stop should be written down and the penalty points calculated after the bout. Should a timekeeping error be made a scorer should advise the centre Marshal immediately so that the bout may be stopped and re-flown.
- (e) The Circle Marshal will be considered to be part of the course and any model or line contact with him will be treated as if it had contacted the ground. It is the flier's responsibility to avoid the Marshal, not the Marshal's to avoid the models or lines.
- (f) Times and scores are public information and should be freely available.

4.4.7.9 The Bout

- (a) A contestant's flight commences after a 30 second period for engine starting. The last 10 seconds to the launch signal shall be counted down by the Circle Marshal.
- (b) The flight shall last four minutes from the launch signal and its completion shall be signalled by the Circle Marshal.
- (c) The engine must be started by flicking the propeller by hand.

4.4.7.10 Scoring

- (a) Scoring will commence at the launch signal and finish at the completion signal.
- (b) One point will be deducted from a contestants score for every full period of 15 seconds that their model is not airborne during the flight period. Ground time is not accumulative and the stopwatch must be zeroed each time the model becomes airborne.
- (c) Four points will be added to a contestant's score for each single cut of their opponent's streamer or string with knot.
- (d) In the event of a mid-air collision, if the streamer falls to earth attached to any part of the model or engine it will not be counted as a cut. If, however, the streamer falls separate to any part of the model a cut will be recorded.
- (e) An organiser may opt to add a further 2 point penalty for each landing. This is to be in addition to any ground penalty. Where an organiser takes this option, it must be introduced at the start of a round and must apply to all bouts flown in that round. It need not apply to the whole competition.

4.4.7.11 Attempts

Only one attempt will normally be allowed to complete a combat heat except for when:

- (a) A streamer breaks in the air due to being faulty. It must be clear that the break was not caused by an attack from the other model.
- (b) In the event of a line tangle resulting in the control line(s) breaking and only one model aircraft being grounded, making it impossible to clear the line tangle.
- (c) If, as a result of a line tangle, an opponent's model aircraft cuts its own streamer in flight or the streamer, unless only string remains, becomes wrapped around the model aircraft and/or the lines, the heat shall be re-flown.

4.4.7.12 Conduct

- (a) A pilot must remain inside the centre circle while his model is flying except at the moment of release of his model by the pitman.
- (b) After a mid-air collision the heat shall continue as if both models had landed.

- (c) If the pilot(s) accidentally leave the centre circle during a combat bout the Centre Marshal must blow his whistle and stop combat although the bout timer will continue to run. He will then direct the flyer(s) back to the centre. The combat will be restarted as at the start of the bout. If the Centre Marshal declares that no one flyer was responsible he need not penalise either. Any cuts taken during the period will not be counted and attacking during the pause may lead to disqualification.
- (d) Mechanics may only enter the flight circle to retrieve a downed model when there is no line tangle or to help clear a line tangle when BOTH models are grounded.
Line tangles when just one model is airborne must be cleared by the pilot and Centre Marshall.
The Centre Marshall will indicate to the mechanics when the line tangle is cleared and that they may enter the flight circle.

4.4.7.13 Offences

If during the servicing of a grounded model the mechanics break or cut the streamer it must be replaced with a new full length streamer prior to launch.

If during servicing the streamer should become entangled and subsequently fail to unfurl the pilot must immediately land to have the streamer untangled or replaced. No additional penalties other than ground time will be incurred.

The following are warnable offences and each and every occurrence will result in a 2 point deduction

- (a) If a pilot unintentionally leaves the centre circle while his model is airborne.
- (b) During the bout the mechanics enter the flying circle at an oblique angle or cut across the flying circle to reach a downed model. One penalty only will be incurred for each offence even if more than one mechanic is involved.
- (c) If the mechanic(s)/pilot do not immediately, or after a line disentanglement, withdraw a grounded model to outside the 20 metre circle prior to servicing it.
- (d) If the model is launched prior to the launch signal.
- (e) If the streamer becomes detached from the model during combat but not as the result of a mid-air collision.
- (f) If a pilot leaves the centre circle without informing his opponent and the Centre Marshal.
- (g) Where in the opinion of the Centre Marshal a competitor deliberately lands to avoid combat he will be penalised 4 points for a first offence. Subsequent offences will be taken care of under rule 4.4.7.14(q).

4.4.7.14 Cancellation of the Flight (Disqualification)

An entrant will be eliminated from the heat and his opponent declared the winner if:

- (a) He deliberately attacks the streamer of his opponent's model prior to the Circle Marshal's signal to commence.
- (b) His model fails to become airborne within two minutes of the signal to launch.
- (c) He attempts to fly a model which at the time of launch does not have a strong effective control mechanism, or does not have a secure engine attachment, or does not have a running engine.

- (d) He interferes with his opponent, or forces his opponent to leave the centre circle.
- (e) He deliberately flies in a dangerous manner.
- (f) He attacks his opponents streamer without his own, or the remaining parts, attached to his model.
- (g) He is not present at his allotted flight time, unless he has the express permission of the Circle Marshal.
- (h) He leaves the centre circle, intentionally whilst his model is flying.
- (i) He flies in such a manner as to inhibit his opponent, or his opponent's pit crew, from clearing any line entanglement.
- (j) He flies other than level in an anti-clockwise direction when only his model is in the air and there is no line entanglement.
- (k) At the start of each bout and after a restart when one or both models have been grounded, both models MUST fly level and anticlockwise and combat MUST NOT commence until a signal is given by the Circle Marshal. Attacking the opponents streamer before this signal will result in disqualification.
- (l) For any other flagrant breach of the rules.
- (m) He releases the handle, or removes the safety strap, for any reason, while the model is flying.
- (n) He deliberately attacks or interferes with his opponents continuously level flying model which clearly has no paper streamer left. He may, however, follow closely.
- (o) He fails to clear any line tangle prior to relaunching his model.
- (p) He flies level (upright or inverted) at a height of less than 6 feet for more than two consecutive laps whilst the bout is under way unless instructed to by the Circle Marshal. the Circle Marshal will warn a flier that he is approaching this limit.
- (q) The Circle Marshal believes that he has behaved in an ungentlemanly manner.
- (r) Where, in the opinion of the Centre Marshal, fliers collude to arrange a result they will both be disqualified from the event by the Centre Marshal and will be allocated points toward any league positions or the Knokke Trophy.
- (s) A flier who does not present himself, or an adequately competent replacement, in adequate time to judge the bout following the bout following that in which he has flown, will be removed from the subsequent draw. The organiser is at liberty to adjust this order but, in any case, a flier will be expected to judge as many bouts as he flies or to provide a suitable replacement to do so.

4.4.7.15 Contest Procedure

- (a) Contestants will normally compete with each other in a knockout competition chosen by random draw. The losers of each of the first round flights will be allowed to compete in a further losers re-fly round. These and any subsequent draws will be held in public and if any member of the organising club or team are involved in the competition then the draw will be made by an unbiased outsider.
- (b) The winners from this round will be drawn with winners from the first round to provide a second round of contests. After losing twice a competitor should not be reinserted. Eliminator rounds should be run to arrive at the correct numbers for quarter and semi finals to proceed.
- (c) The rounds will continue until eight contestants are left so that quarter, semi and final round provide an overall winner

- (d) It is permissible for the competition organiser to seed the draw on past results and known form but members of the same team or club should be drawn apart as far as possible. The seeding committee must be neutral. Where an unseeded competitor eliminates a seeded one he will assume that seeding position for the remaining draws.
- (e) The avoidance of members of the same club being drawn to fly together will take first priority when making any draw.

4.4.8 OLIVER TIGER COMBAT

The object of this class is to provide a class of combat that is comparatively cheap to compete in and where the performance levels can be kept down to a level by strict control of model design and engine modification. The rules are based upon those of Vintage Combat, however, this is not a nostalgia class but an entry level sport.

The rules for Class 4.4.7 Vintage Combat will apply with the following exceptions:-

4.4.8.1 The Model

Models may be covered in any material including modern film.

The Vintage Combat eligible model list will apply with the following additions:

MODEL	DESIGNER	SOURCE	DATE
Black Ghost	M.Grimmett (UK)	M.A.295	Nov 1958 p360
Early Bird	Richard Wilkins (UK)	M.A.1022	Sep 1965 p232
Firebird	Dave Platt (UK)	Keil Kraft Kit	
Peacemaker	George Aldridge (USA)	A.M.687	Feb 1959 p68

4.4.8.2 Engine

- (a) Engines in this class should be either genuine Oliver Tiger Mk3 or Mk4 (John Oliver or Tom Ridley) or their clones (Russian, Chinese or Parra T3). The only permitted modifications will be chroming and the removal of metal from the original manufacturers' standard parts. The replacement of the compression screw and carburettor assembly with non-original parts is permissible.
- (b) All Oliver Tiger Combat models are subject to a speed limit of 30 seconds for 10 laps.

This is to be measured without the streamer and with the handle on the pilot's chest. Any flyer found to be exceeding the speed limit must demonstrate to the Contest Director that he is within the speed limit before being allowed to re-fly the bout. Otherwise he will be eliminated from the competition.
- (c) The engine must be fitted with a domed safety nut.
- (d) Only suction feed fuel systems are permitted.
- (e) Any engine may be stripped for inspection at any time that the Contest Director may decide.

NOTE It is intended that engine modifications will be strictly policed and any modification that gives an obvious advantage will be banned as soon as it becomes apparent, hence 4.4.8.2.(e) above.

4.4.8.3 Officials

- (b) The Centre Marshal may at his own discretion remain outside the circle for safety purpose.

4.4.10 BMFA VARIATIONS ON F2E DIESEL COMBAT

- (a) As the majority of models used in this class in the U.K. are purchased already built and these are supplied without the wire from the bellcrank to the motor, Rule 4.4.5.5 will not be enforced until further notice.

4.4.10.1 Contest Procedure

Under normal circumstances the contest will be run as 4.4.(1).16 (a) to (i) except where the number of entries does not permit this. Should this situation arise the following system will be used:

- (a) Contestants will normally compete with each other in a knockout competition chosen by random draw. The losers of each of the first round flights will be allowed to compete in a further losers re-fly round.
- (b) The winners from this round will be drawn with winners from the first round to provide a second round of contests.
- (c) The rounds will continue until eight contestants are left so that quarter, semi and final round provide an overall winner.

4.4.10.2 Engine

Any engine/model combination eligible for Vintage Combat may be used.

4.4.10.3 Pilot

The pilot must wear protective headgear with the strap fastened throughout the bout.

4.4.10.4 Line Changes

Line changes are allowed during the combat period. One model per match shall be allowed. Engine changes are NOT allowed. The changed lines will be pull tested by the centre marshal. Replaces rules 4.4.5.7 (b) & 4.4.5.12 (c)

4.4.10.5 'Fly Away'

A "fly away" shall be defined as going outside a pre-determined area set by the organisers. At the Nationals this will be the "roped off area". Clarifies rule 4.4.5.12(b)

4.5.1 CLASS 1 CARRIER DECK

4.5.1.1 The Flight Deck

The specifications of the flight deck should be as close to those of the deck constructed by the Royal Navy as possible except that when no deck is available for the event, weighted drags and arrester wires on any flat surface may be used.

4.5.1.2 Model Specific

The model must take off and land on an undercarriage of fixed or retractable type; in the latter case, the wheels must be extended for landing. Models must be equipped with an arrester hook which will have a maximum extended length of less than 1/3 of the model's overall length. Models must fly in an anti-clockwise direction. No method may be used to assist take-off other than the thrust developed by the in-flight power unit.

4.5.1.3 Lines

Stranded cable of minimum diameter 0.0136 inch (e.g. light Laystrate) will be used for two line systems for engines up to 0.40 in³ (6.55 cm³). Stranded cable of minimum diameter 0.018 inch (e.g. heavy Laystrate) will be used for two line systems for engines from 0.40 to 0.60 in³ (10 cm³). Additional lines may be of any diameter. The lines shall be 60 ft (plus 6", minus 0") from the grip of the grip of the control handle to the centre line of the model. Model, lines and handle shall withstand a pull test of 20 times the weight of the model.

4.5.1.4 Official Flights

Three minutes will be allowed from the competitor beginning to start his engine, for the model to become airborne. Exceeding this time allowance will cause an attempt to be recorded. A further two minutes is allowed for each additional engine of a multi-engined model. An attempt will also be recorded where the model has been released for a take-off. Three attempts will be allowed for the two official flights, the highest scoring flight to count for the purposes of determining the competitor's placing. A flight is considered official when the competitor signals for a timed, low-speed run. In the case of an uncompleted flight programme, points will be scored for the parts carried out, and also for the scale. All ground other than the deck shall be considered water, and touching the ground will terminate the flight.

In the final classification those competitors who have scored landing points under rule 4.5.1.7 will be placed ahead of any competitor who has failed to score landing points regardless of total scores.

4.5.1.5 Flight Procedure

The model shall not exceed an altitude of 20 ft. for more than half a lap during the timed run. No whipping is allowed at any time. High speed flight will be the first seven laps of the flight timed from a standing start. Low speed flight will be the next seven laps after the competitor signals the start of his low speed run by a pre-arranged signal, and this will be timed from passing over the stern of the carrier. The flyer will not walk a circle of larger than 3 ft. radius during this phase of the flight.

4.5.1.6 Flight Scores

Speed points will be scored as four times the percentage of the speed made by the differential between low and high speed, as calculated by the following formula:

$$\frac{(H - L) \times 100 \times 4}{H} \quad \text{Where } H = \text{high speed and } L = \text{low speed}$$

Example: High speed = 95 mph, low speed = 25 mph.

$$\frac{(95 - 25) \times 100 \times 4}{95} = 295 \text{ points}$$

4.5.1.7 Landing

The competitor shall signal to the judges when he is ready to land. The landing takes place at the end of the next complete lap after signalling, any subsequent laps being penalised by the deduction of 5 landing points for each extra lap. It is desirable that a centre marker be provided, approximately 18 inches square and not more than 1/2 inch thick, to assist the competitor in lining-up for the landing.

Points will be scored as follows:

- (a) 100 points for an arrested landing ending with the model at rest at the normal ground angle for the type of undercarriage used.
- (b) 50 points for an arrested landing ending with the model at rest at any other angle, while still having both main wheels in contact with the deck.
- (c) 25 points for a landing on the deck, ending with the model at rest in any position not fulfilling the requirements of (a) and (b) above.

4.5.1.8 Scale Bonus

A carrier aircraft of any nation shall score 100 scale bonus points. A carrier aircraft is defined as any full-size aircraft which has at any time been fitted with arrester equipment designed for deck landing.

4.5.1.9 Scale Scoring

For the purpose of this contest, scale bonus points shall only be awarded to a model with fuselage, air brakes and the outlines of wings, tailplane, elevators, flaps, fin and rudder to the same scale within a tolerance of plus or minus 5% in line or dimension. Undercarriages shall emerge from the model in the same place as the prototype but need not be to scale. It is not necessary for flaps to operate in the same manner as the prototype. Engine and accessories may protrude from the contours of the model providing the clearance around the protruding part does not exceed 1/4 inch. Wing dihedral shall be plus or minus 1%. If a clear canopy is not used, the cockpit or canopy area shall be defined with a contrasting colour or colour outline. Colour schemes and markings shall approximate to a scheme used on the prototype. Scale three view drawings must be submitted to qualify for bonus points. The drawings shall be from a source acceptable to the contest director. Any deviation from these definitions and tolerances will result in NO scale points being awarded.

4.5.3 BASIC CARRIER DECK With thanks to the Three Kings Club

4.5.3.1 The Model

- (a) Any fixed wing model which must have a stable wheeled undercarriage.
- (b) Any engine, throttled or unthrottled.
- (c) No tuned pipes, only effective standard silencers.
- (d) Any line length.
- (e) No moveable surfaces except normal elevators for pitch control, no yaw variation methods such as line rakes and no fixed boundary layer control devices such as slots or slats.
- (f) The arrester hook to be no longer than one third of overall model length and to have no other function other than to arrest the model on landing.
- (g) A spinner or safety spinner nut is compulsory.
- (h) All handles must be fitted with a safety wrist strap which must be used by the pilot.
- (i) All models, ready to fly, shall be subject to a pull test of 15 times model weight sustained for ten seconds.
- (j) All models must be fitted with a heavyweight Laystrate (or equivalent) safety cable between the bellcrank pivot and the engine.

4.5.3.2 The Contest

- (a) A competitor is allowed a maximum of three attempts to make a maximum of two official flights. An official flight is recorded when the pilot signals the start of the slow flight; until that time the flight is considered an attempt. Once two official flights have been recorded by a competitor they will be allowed no more attempts (subject to a CD's decision to extend the contest on the day)
- (b) An attempt begins as soon as you have begun to start your engine(s). You are allowed three minutes to start the engine (four minutes for multi engine models).
- (c) The model is timed from a standing start on the deck (or ground if the deck is not used) for seven full laps and the high speed time is recorded in seconds. The CD will signal when these laps have been counted.
- (d) For the low speed score, on the pilot's signal the model is timed from a point above the carrier's stern for a full seven laps and the low speed score is recorded in seconds. The CD will signal when these laps have been counted.
- (e) Flying height is not to exceed 6 m (20 ft) throughout the whole attempt and you must not leave the 3 m diameter pilot's circle during the flight. Flight progress must always be forward and anticlockwise. Ground contact, except after landing, is considered to be ditching and is not allowed. Any infringement of these requirements means disqualification from the attempt.
- (f) Model attitude should not exceed 45° to the horizontal. Except after the landing signal each exceedance of 45° for one second or less will incur a warning and three warnings will disqualify the flight. After the landing signal has been given, a single exceedance of 45°, however momentary, will disqualify the flight without warning.
- (g) To assist in assessing the 45° model angle a clearly visible line shall be painted (or adhesive tape may be used) on both sides of the fin such that the line is horizontal when the model is held at 45° nose up.

- (h) On the pilot's signal of readiness, the model is to land on the deck or the marked-out deck outline after the next approach. Each lap completed after this first approach will result in a five point deduction.
- (i) The quality of the landing will be assessed and points will be awarded as follows:
 - (i) Arrested, when stationary the model has correct deck attitude for wheel arrangement 100
 - (ii) Arrested, when stationary the model does not conform to (i) but has all main wheels on deck 80
 - (iii) Arrested, when stationary the model does not conform to (i) or (ii) but is still on deck 60
 - (iv) Not arrested, when stationary the model has correct deck attitude for wheel arrangement 40
 - (v) Not arrested, when stationary the model does not conform to (iv) but is still on deck 20
 - (vi) Any part of model makes ground contact, whether arrested or not 0
- (j) Models judged to be of scale like appearance of a specific navy aircraft that has made an arrested landing on an aircraft carrier will be awarded 10 bonus points. Models painted in a navy-like colour scheme will be awarded 10 bonus points. If the model has both it will be awarded 20 points.
- (k) The Contest Director's decision on all matters is final.

4.5.3.3 The Results

- (a) The competitor's highest individual flight score counts.
- (b) An individual flight score is: Low Speed (in seconds) minus High Speed (in seconds) plus Landing Points plus Appearance Points minus Deductions.
- (c) All times will be recorded to the nearest one tenth of a second.

NOTES

NOTES

BRITISH MODEL FLYING ASSOCIATION

SMAE Ltd

Chacksfield House, 31 St Andrews Road, Leicester, LE2 8RE

Telephone - 0116 2440028 Fax - 0116 2440645

E-Mail - admin@bmfa.org Website - <http://www.bmfa.org>